

# INSTRUCTION SHEET (original)

## SAFETY RELAY MODULE

### HR2S Series

(HR2S-332N-T075 (Ver.2), HR2S-332N-T15 (Ver.2), HR2S-332N-T30 (Ver.2))

Confirm that the delivered product is what you have ordered. Read this instruction sheet to make sure of correct operation. Make sure that the instruction sheet is kept by the end user.

#### NOTE

- The contents of this document may be revised without prior notice.
- No part of this document may be reproduced or revised without the written permission of DEC CORPORATION.
- All other products, brands, or trade names used in this document are the trademarks or registered trademarks of their respective trademark owners.

#### SAFETY PRECAUTION

In this operation instruction sheet, safety precautions are categorized in order of importance to Warning and Caution:

#### WARNING

Warning notices are used to emphasize that improper operation may cause severe personal injury or death.

#### CAUTION

Caution notices are used where inattention might cause personal injury or damage to equipment.

#### WARNING

- For safe operation, be sure to turn off the power supply of the module before wiring or installation.
- Use within the specified voltage. Do not use power supplies that produce high ripple voltage or abnormal voltage.
- Do not use the module with an electrical load that exceeds the switching capacity.
- Do not use the module in places where inflammable or explosive gases exist. Otherwise, fire or explosion may occur due to switching of contacts.
- The module is designed for use in typical machinery manufacturing facilities. This module shall not be used for nuclear controls, train, aeronautics, automobiles, engines, medical, or entertainment devices or facilities.
- This module doesn't have TÜV SÜD certificate for EN/IEC 61496-1: 2013.
- Leave spaces of more than 5 mm from the sides of the module when an electricity of 3 A or more is continuously applied to the relay contact.

#### CAUTION

- The category of the control system (hereinafter called category) is determined with the entire control system.
- Determination of category and performance level for the control system (design of the safety-related parts of the control system) must be performed by safety experts.
- This module is classified as overvoltage category III. Make sure to take appropriate measures when designing this control system.
- Life of the module depends on conditions such as switching and electrical loads. Before operation, be sure to test under actual conditions and within the switching capacity.
- Use this module in a completely sealed control panel. Also, leave spaces of more than 5 cm from the top and the bottom of the module.
- The performance may be decreased when used in an environment where density of dust, cutting oil, and an organic solvent, are comparatively high. Contact DEC for details.
- Resettable fuse is installed in the control circuit for prevention of over current. If the switch is activated, turn off the module. When the problem is resolved, turn on the power again.
- When disposing of this module, handle it under the laws and regulations of the country in which it is disposed.

#### WARRANTY

- Before using the module, make sure that the sealing sheet is affixed on the main body.
- Modules without a sealing sheet are excluded from the scope of warranty.
- Modules that have been dropped, damaged, or disassembled are excluded from the scope of warranty.

### 1 Scope

This specification applies to HR2S of the safety relay modules.  
Subject model types: HR2S-332N-T075 (Ver.2), HR2S-332N-T15 (Ver.2), HR2S-332N-T30 (Ver.2)

### 2 Outline

- This safety relay module satisfies with Category 3 or 4, Performance Level e according to EN ISO 13849-1:2015.
- Two types can be selected according to difference of safety stop input. However, in some cases, Category 3 or 4 or Performance Level e cannot be satisfied depending on the circuit where the module is used. See Section 9 for details, and make sure that required safety level is achieved before using of this module.
- Automatic reset (AUTO) and Manual reset (MANU) modes can be selected by switching the AUTO/MANU switch on the front of the module.
- "AUTO" starts immediately when safety input and start / off-check (reset) input are closed. (No monitoring of start switch)
- "MANU" starts when safety input and start / off-check (reset) input are closed and then safety input and start / off-check (reset) input are opened. (With monitoring of start switch)
- Set up the module according to use.
- After the switch is set, affix the supplied protective film to prevent from changing the setting.
- Off-delay timer variations
- The products whose model No. is "-T\*\*\*" have the off-delay timer output contact interlocked with the safety output. \*\*\* of "-T\*\*\*" is the maximum timer value which can be set up.

### 3 Dimensions and Parts Description

#### 3.1 Dimensions [mm]

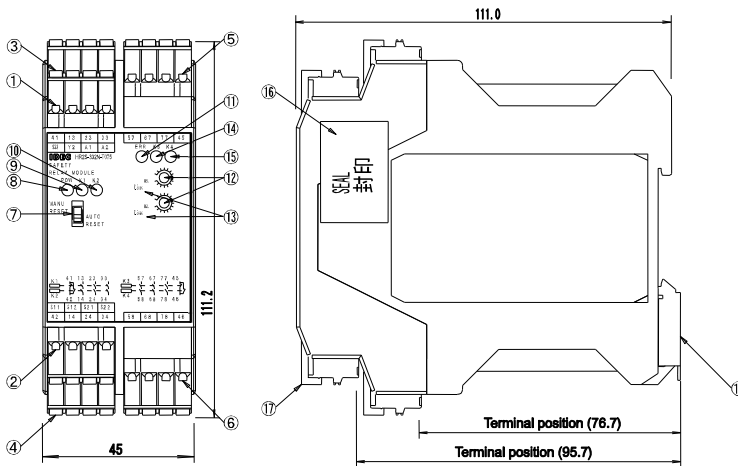

#### 3.2 Parts Description

Parts No.	Parts Names and Functions
1	CN1: Power supply input and start / off-check input
2	CN2: Safety input (in 2 systems)
3	CN3: Safety output contact
4	CN4: Safety output contact
5	CN5: Off-delay output contact
6	CN6: Off-delay output contact
7	Switch: Select AUTO or MANU start mode
8	POW: Power supply LED
9	K1: ON-LED for safety output system 1
10	K2: ON-LED for safety output system 2
11	ERR: Error (timer) LED
12	Select switches: Use to set off-delay time. Set the same value for the two switches, otherwise an error will occur.
13	Instruction marking: Indicate the max. Off-delay time. "075: 7.5sec", "15: 15sec", "30: 30 sec"
14	K3: ON-LED for off-delay output system 1
15	K4: ON-LED for off-delay output system 2
16	Sealing Sheet: 1 piece of sealing sheet is affixed on the side face of the main body. Modules without sealing sheet are excluded from the scope of warranty.
17	Terminal Cover: To prevent falling off of connectors CN1 to CN6 and to make sure that the connectors are properly installed.
18	DIN Rail mounting bracket

### 4 Installation and Wirings

#### 4.1 Installation

Mount the module to the panel using DIN rail (35 mm wide). This module can be mounted in any direction. Install the module in a control panel with a protection degree of P54 or more. For DIN rails, use a mounting clip to prevent the module from falling off. IDEC's mounting clip (BNL6) can be used.

#### 4.2 Wiring

- Use wire of sizes as specified as follows.  
Stranded wire (flexible wire): 0.2 to 1.5 mm<sup>2</sup>, AWG 24 to 16  
Solid wire (steel wire): 0.2 to 1.5 mm<sup>2</sup>, AWG 24 to 16
- Connect after terminating the stranded wire with ferrule (sleeve type). Use cables conforming to the applicable standards.
- Close the terminal cover after the wiring is complete.
- If the terminal cover does not close, the connector may not be fully inserted.
- (\*)Before wiring, check that the electrical wires can be used without problems. Connect no voltage contacts to Inputs S11 - S12 (S21 - S22).
- Precautions when using multiple HR2S modules.  
A single switch (see SW1 in the diagram below) cannot be connected to multiple inputs. Use switches with independent contacts.
- (Do not connect one safety device to multiple HR2S safety inputs in a parallel connection)

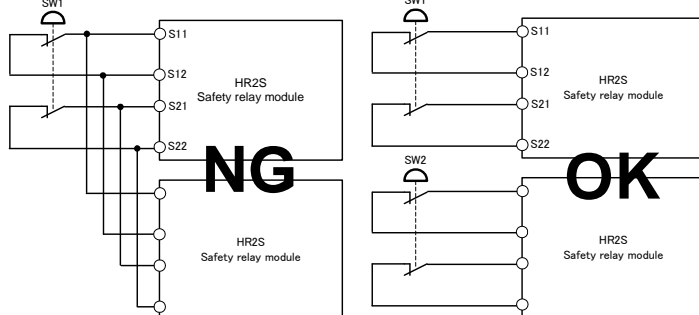

Note) Same for start / off-check input

- Power supply terminal  
Be sure to use a switching power supply that complies with EMC Directive and IEC 60950, and NEC CLASS2 for an external power supply. Inverse connection of the power supply may result in breakage.
- Sleeve type ferrule  
Use crimping metal terminals with length of 8-10 mm.  
Ref. MFR: Widemular  
Type No.: H0.5/14, H0.5/16, H0.75/14, H0.75/16, H1/14, H1/16, H1.5/14, H1.5/16  
MFR: PHOENIX CONTACT  
Type No.: AI0.5-8, AI0.5-10, AI0.75-8, AI0.75-10, AI1-8, AI1-10, AI1.5-8, AI1.5-10

#### Wiring termination

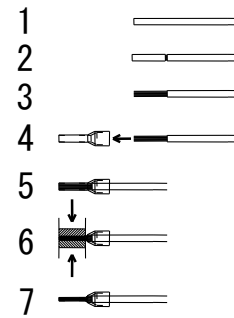

#### Termination process

#### Connecting the wiring with the terminal

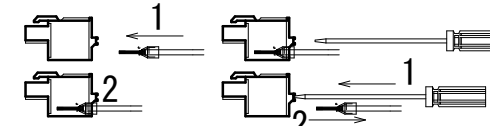

#### Connecting the wiring

- Connecting the module and terminal  
Close the terminal cover after the wiring complete.  
If the terminal cover does not close, the terminal may not be fully inserted.

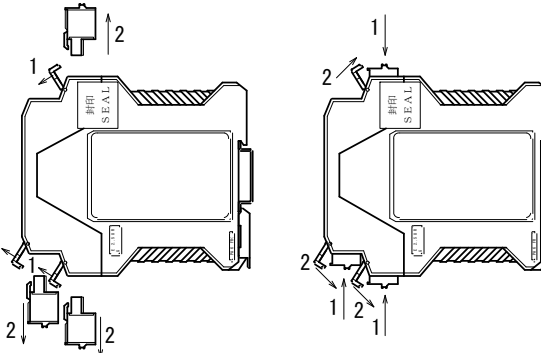

#### Removing the terminal

#### Connecting the terminal

#### 4.3 Wiring length

The external wiring length of a safety input and start / off-check input is specified as follows. IDEC does not guarantee normal operation if wire length other than specified is used.  
Safety input: Up to 50 m in total (wiring resistance: 5 ohm maximum)  
Start / off-check input: Up to 50 m in total (wiring resistance: 5 ohm maximum)

#### 4.4 Maintenance

Replace with a new module when damaged.

### 5 Input/Output

Terminal	Markings	I/O Signals	Notes
CN1	A1	Power supply +24V DC input	
	A2	Power supply 0V input	
	S33	Start / off-check input	Use no voltage contact.
	Y2		
CN2	S11	Safety input 1	Common side
	S12		
	S21	Safety input 2	Common side
	S22		
CN3 CN4	41-42	Monitor contact for safety output (NC)	Rated load 250 V AC/ 30V DC, 1A (Resistive load)
	13-14 23-24 33-34	Safety output contact (NO)	Rated load 250 V AC/ 30V DC (Resistive load)
	45-46		
57-58 67-68 77-78	Off-delay output contact (NO)		

#### \*NOTES

- Leave spaces of more than 5 mm from the side of the module when an electricity of 3A or more is continuously applied to relay contact.
- For CN1 and CN2 terminals, be careful of surges applied by other wiring. Damage may be caused.
- Safety output contact is limited according to standards. See Sub-clause 9.1 for details and Section 8 about the fuse.

### 6 Wiring Diagram

#### 6.1 Internal Circuit

HR2S-332N-T\*\*\* (Ver.2)

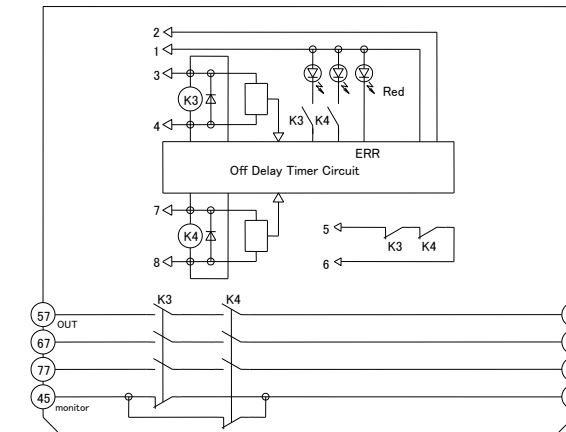
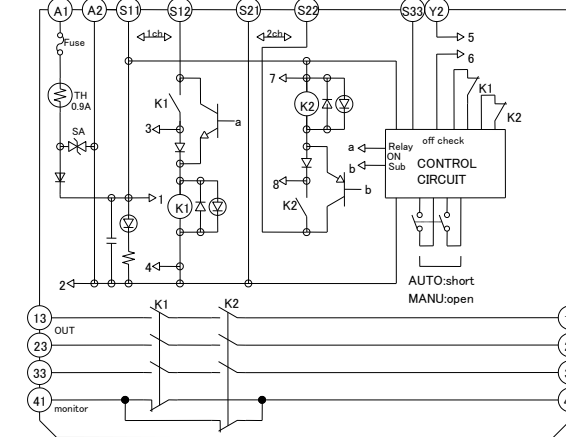

#### 6.2 Wiring Diagram

AUTO start mode

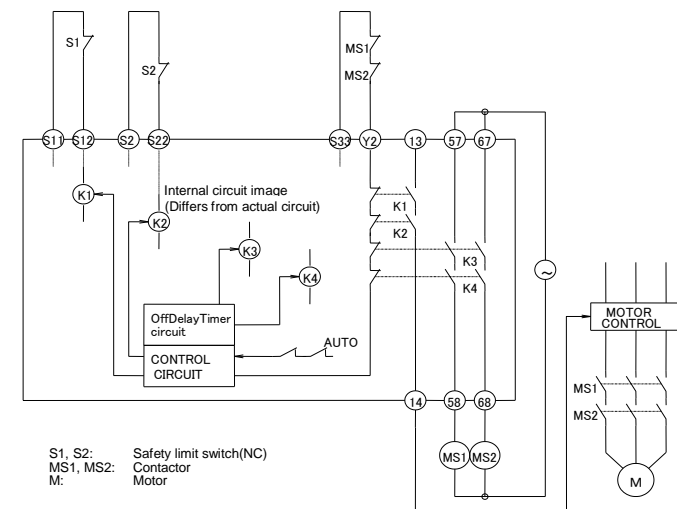

#### AUTO action

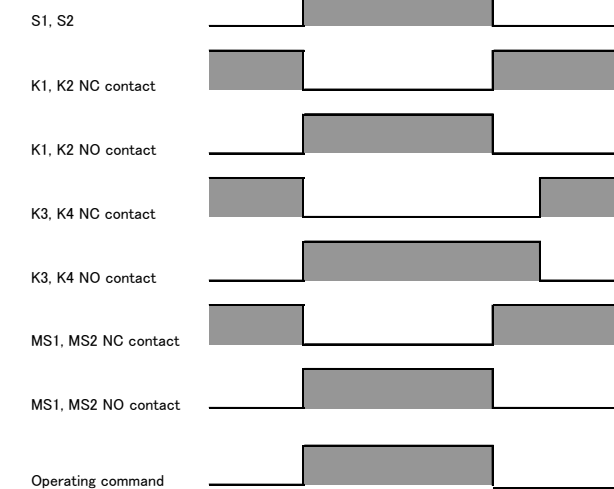

OFF-delay time

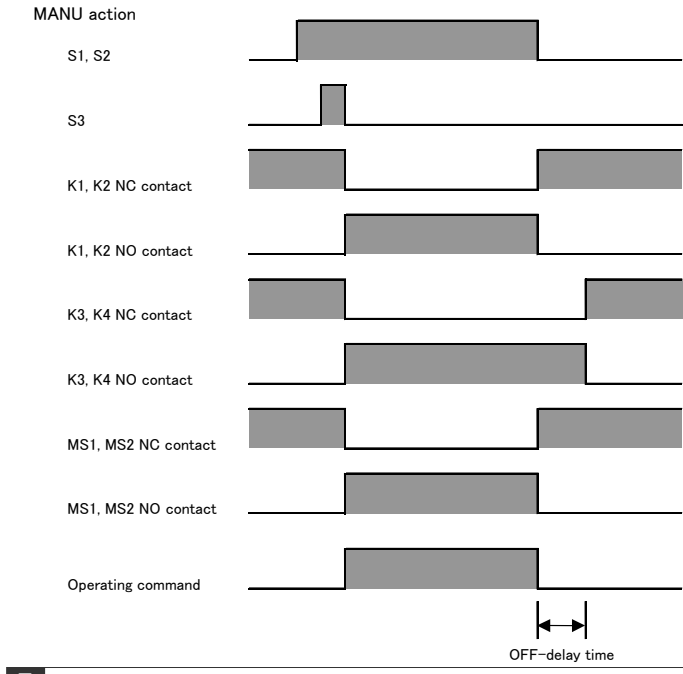
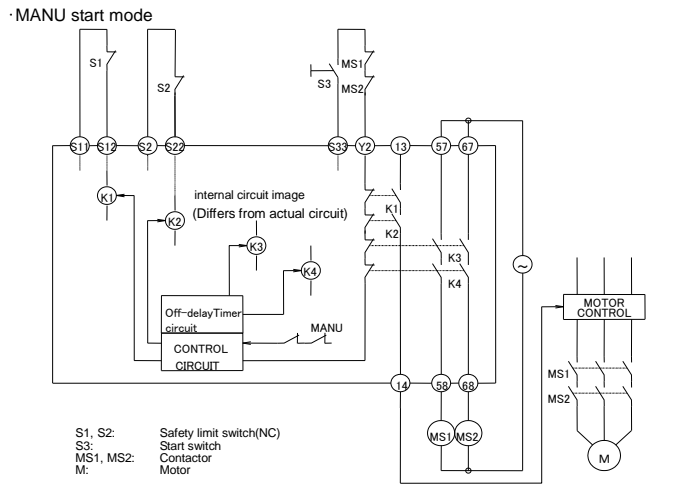

## 7 Control Devices in Connection

- Emergency stop switches  
Use emergency stop switches that comply with EN / IEC 60947-5-1 or EN/ IEC 60947-5-5 and have direct opening action mechanism.
- Interlock switches  
Use Interlock switches that comply with EN / EC 60947-5-1 and have direct opening action mechanism.
- Electromagnetic switch  
Use reliable electromagnetic switches that are force guided types.  
If a NC contact of electromagnetic switches without force guided contact is connected to start / off-check input, failure of electromagnetic switch contacts cannot be detected.
- Protection of contact output  
For inductive load, it is recommended that users should provide a surge absorber to output contacts to prevent the contacts from welding.  
When an overvoltage larger than the value rated for output contact is expected, provide a fuse with output contact.
- When connecting other control devices: Use the device after verifying that it complies with the required category.

## WARNING

Be sure to turn off the power before when switching between AUTO/MANU  
Below are cautions for the start / off-check input. For the start / off-check input, use devices with back check functions (mirror contact). When using other than those specified, it may cause a hazardous situation by failure of combination with other failures.

AUTO mode:  
It is forbidden to use the start switch.  
Otherwise, the contacts of the start switch may weld and may cause unexpected operation that could lead to hazards.

MANU mode:  
When using the start switch, be sure to use NO (normally open) momentary type.  
Use reliable device for start switch. This safety relay module has internal circuit to block the start when start switch has malfunction. When this safety relay module is not started, remove the cause of short malfunction and replace the start switch.

## 8 Fuse

To satisfy category 4, use a fuse which limits the current to maximum 3.6 A, this fuse is not required if the prospected short circuit current is less than 5 A.  
These measures prevent the contacts from welding. See EN 50156 and Sub-clause 9.1 for details.

## 9 Safety Category, Stop Category and Performance Level

When applying EN ISO 13849-1 2015 to machinery, perform risk assessment of the machinery and make sure to achieve the Performance Level (PL) greater than the required Performance Level (PLr) for each safety function. (PLr ≤ PL)  
Also, Stop Category is required for machinery, and its system must be so arranged as to satisfy the required Stop Category.

The following section describes Category, Stop Category, Performance Level and notes.  
Notes:  
The following figures show the concept of this module.

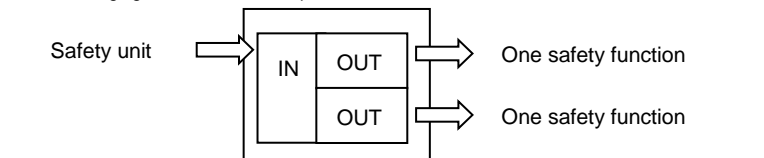

9.1 Category  
HR2S series can be used in environment of Category 3 or 4 required by EN ISO 13849-1:2015. However, Category 3 or 4 may not be satisfied depending on conditions of use. The following table shows Category of each safety segment according to safety input, safety contact output, and safety devices to be connected.

Type No.	Output type of the safety device connected to the safety input	Rating of safety output contact (A) Note 1	Available Category
HR2S-332N-T*** (Ver.2)	Contact output (safety output)	5 or less 3.6 or less	3 4

Note 1) Protection by fuse according to EN 60159 is required.

9.2 Stop Category  
Safety output contact: Stop category 0  
Off-delay output contact: Stop category 1  
Emergency stop control according to Stop Category 0 or 1 defined in EN / IEC 60204-1 is feasible. However, Stop Category 0 or 1 may not be satisfied depending on conditions of use. Because the stop category is determined by control system take the connected safety equipment and wiring into consideration.

9.3 Performance Level  
HR2S series satisfies with Performance Level e according to EN ISO 13849-1: 2015. However Performance Level e may not be satisfied depending on conditions of use. Calculate the Performance Level of each safety function based on device used for safety input, device connected to output contacts, and HR2S (factors as shown below), and make sure that the satisfied Performance Level equals to or be better than the required Performance Level.

Calculation Data of Performance Level for the entire system (machine)

Type No.	MTTFd	DCavg	CCF
HR2S-301N-T*** (Ver.2)	100 years min.	99%	88 points

Calculate the Performance Level per each safety function.

## 10 Specifications

### 10.1 Module Type

Type No.	Product type	Safety output contact	Monitor contact for safety output	Off-delay output contact	Monitor contact for off-delay output
HR2S-332N-T075 (Ver.2)	Safety relay module (Negative type) with off-delay timer (7.5s)	3NO	1NC	3NO	1NC
HR2S-332N-T15 (Ver.2)	Safety relay module (Negative type) with off-delay timer (15s)	3NO	1NC	3NO	1NC
HR2S-332N-T30 (Ver.2)	Safety relay module (Negative type) with off-delay timer (30s)	3NO	1NC	3NO	1NC

NOTES:  
· Off-delay time can be set in 15 steps.  
7.5 sec. (0.5, 1.0, 1.5 7.0, 7.5) ; 15 sec. (1, 2 14, 15) ; 30 sec. (2, 4 28, 30)  
· Products fall into two categories depending on the wiring method.  
See Sub-clause 9.1 for details.

### 10.2 Specification

Type No.	HR2S-332N-T*** (Ver.2)		
Overvoltage Category	III (IEC60664-1)		
Pollution Degree	2 (IEC60664-1)		
Insulation	Basic insulation (Output contact circuits and an internal circuit have reinforced insulation)		
Rated Voltage	24V DC (Tolerance: -15% to +10%)		
Rated Current Consumption	165mA		
Rated Power Consumption	4.6W		
Category and Performance Level (According to EN ISO 13849-1:2015)	Category 3 or 4, PL e		
Stop Category (According to EN / IEC 60204-1)	0, 1 (NOTE 1)		
Safety Output Contact	Configuration	3NO 1NC	
	Terminals: 13 to 14 23 to 24 33 to 34 (NO-Contact Output)	Rated Load (NOTE 2, 3, 9)	250V AC / 30V DC (NOTE 10) (Resistive load)
		EN60947-5-1 Table 4	AC15 240V AC, 2A, cosφ=0.3 DC13 24V DC /1A, L/R=48ms
	Number of outputs	3 (NO-Contact Output)	
Safety Output Contact	Configuration	3NO 1NC	
	Terminals: 41 to 42 (NC-Contact Output)	Rated Load (NOTE 3)	250V AC / 30V DC, 1A (Resistive load)
		EN60947-5-1 Table 4	AC15 240V AC, 2A, cosφ=0.3 DC13 24V DC, 1A, L/R=48ms
	Number of outputs	1 (NC-Contact Output)	
Off-delay Output Contact	Configuration	3NO 1NC	
	Terminals: 57 to 58 67 to 68 77 to 78 (NO-Contact Output)	Rated Load (NOTE 2, 3, 9)	250V AC / 30V DC (NOTE 10) (Resistive load)
		EN60947-5-1 Table 4	AC15 240V AC, 2A, cosφ=0.3 DC13 24V DC /1A, L/R=48ms
	Number of outputs	3 (NO-Contact Output)	
Off-delay Output Contact	Configuration	3NO 1NC	
	Terminals: 45 to 46 (NC-Contact Output)	Rated Load (NOTE 3)	250V AC / 30V DC, 1A (Resistive load)
		EN60947-5-1 Table 4	AC15 240V AC, 2A, cosφ=0.3 DC13 24V DC, 1A, L/R=48ms
	Number of outputs	1 (NC-Contact Output)	

Contact Resistance (initial value) (NOTE 4)	200mohm max.	
Turn On Time (NOTE 5)	50ms max.	
Response Time (NOTE 5, 6)	20ms max.	
Insulation Resistance (NOTE 7)	100Mohm min.	
Dielectric Voltage	Outer case to internal circuit	3,750V AC, 1mA max., 1 min.
	Between output electrodes	2,500V AC, 1mA max., 1 min.
	Between input-output	
Between power supply output		
Overcurrent protection for control circuit	Resettable fuse installed (approx.0.9A) (NOTE 8)	
Overcurrent protection for output circuit	External installation (NOTE 9)	
Vibration resistance	10 to 55 Hz, 1 octave/min, 0.7 mmp-p X, Y and Z directions, 20 sweep	
	5 to 55 Hz, 30 m/s <sup>2</sup> , 2h for each X, Y and Z direction	
Bump	100 m/s <sup>2</sup> , Pulse width 16 msec, 1,000 times for each X, Y and Z direction	
Shock resistance	300 m/s <sup>2</sup> , Pulse width 11 msec, 3 times for each X, Y and Z direction	
Electrical Life	100 thousand times min.	
Mechanical Life	5 million times min.	
Durability Time for Connector Insertion/Pull out	10 times max.	
Operating Temperature	-10 to 55°C, no freezing, non-condensing	
Storage Temperature	-25 to 70°C, no freezing, non-condensing	
Operating Humidity	30 to 85%RH, non-condensing	
Storage Humidity	30 to 85%RH, non-condensing	
Corrosion Immunity	Atmosphere free from corrosive gases	
Altitude	Operation 0 to 2000m	
Housing Material	PA 66-FR(UL94 V0)	
Degree of Protection	IP20 for terminal block, IP40 for main body	
Weight	320g max.	

NOTE1: Safety output contact: Stop category 0  
Off-delay output contact: Stop category 1  
NOTE2: Leave spaces of 5 mm at the sides of the module when an electricity of 3 A or more is continuously applied to relay contact.  
NOTE3: Minimum applicable load is 24 V DC, 5mA (ref. value)0. Do not apply load that exceeds the specified load.  
Once a large load is applied, it may disable switching of contacts at small loads.  
NOTE4: With voltage drop method at 5 or 6V DC, 1A.  
NOTE5: When measured at the rated voltage (at 20 °C). Excluding contact bounce time.  
NOTE6: The interval between when safety input turns off and safety output contact turns off  
NOTE7: 500 V DC megger, same measurement positions as the dielectric strength.  
NOTE8: At operating temperature of 20 °C.  
NOTE9: To prevent the safety output contact from overcurrent, use a fuse. See Section 8.  
NOTE10: The maximum current at safety output contact is specified by standards for which certification was granted. See Sub-clause 9.1.

When this module is used as shown below, an error may occur.  
-Synchronous time of safety inputs (S11-S12 and S21-S22) is over 20ms  
-Only one of safety inputs is turned off and on after both of safety inputs are ON state.  
-ON time of safety inputs are shorter than turn on time of this module.  
-Safety inputs are turned on during off-delay function is worked.  
When the error occurs, error LED is illuminated and this module become lockout state.  
Turn on again power supply after turn off to regress this module.

### 10.3 Applicable Standards and Declaration of Conformity

EU Declaration of Conformity		
Identification of the Product : Safety Relay Module		
Name and address of Manufacturer : IDEC CORPORATION 2-6-64 Nishimiyahara, Yodogawa-Ku, Osaka 532-0004 Japan		
Name and address of the authorized representative : APEM SAS 55, Avenue Edouard Herriot BP1, 82303 Caussade Cedex, France		
This declaration of conformity is issued under the sole responsibility of the manufacturer. Object of the declaration : Series Name – HR2S Series Model No. – HR2S-301P (Ver.2), HR2S-301N(Ver.2), HR2S-332N-T075(Ver.2), HR2S-332N-T15(Ver.2), HR2S-332N-T30(Ver.2)		
The object of the declaration described above is in conformity with the relevant EU harmonization legislation : 2014/35/EU Low Voltage Directive 2006/42/EC Machinery Directive 2014/30/EU Electromagnetic Compatibility Directive 2011/65/EU and (EU) 2015/863 RoHS Directive Applied Union harmonized legislation and references to the relevant harmonization standards used or references the other technical specifications in relation to which conformity is declared. EN 60947-5-1 2017, EN 50178:1997, EN 60204-1:2018, EN ISO 13849-1 2015, EN IEC 61000-6-2:2019, EN 55011 2016/A1:2017, EN 61326-3-1:2017, EN 50581:2012		
If you need the original EU declaration of conformity, please offer to our sales person or agency.		

	Applicable Standards	Approval
UL Standard	UL508 Industrial Control Equipment	TÜV SÜD NRTL
CSA Standard	CAN/CSA C22.2 No.14 Industrial Control Equipment	