

INSTRUCTION SHEET



LF1D/LF2D LED Illumination Unit LF1D/2D-FL Series

Confirm that the delivered product is what you have ordered. Read this instruction sheet to make sure of correct operation. Make sure that the instruction sheet is kept by the end user.

Safety Precautions

In this operation instruction sheet, safety precautions are categorized in order of importance to Warning and Caution :

WARNING

Warning notices are used to emphasize that improper operation may cause severe personal injury or death.

CAUTION

Caution notices are used where inattention might cause personal injury or damage to equipment.

WARNING

- Before designing the final equipment and powering up the LF1D/2D-FL illumination unit, confirm the specifications scribed on this sheet. If there is any uncertainty in the description, contact IDEC before powering up the LF1D/2D-FL illumination unit.
- The LF1D/2D-FL illumination unit is for indoor use only. Do not use outdoors. Otherwise insulation failure, electric shocks, or malfunction will be caused.
- Do not disassemble, repair, or modify the LF1D/2D-FL illumination unit, otherwise severe accidents may result, such as electric shocks, damage, fire, or malfunction.
- Turn off the power to the LF1D/2D-FL illumination unit before wiring. Make sure of correct wiring, otherwise electric shocks or damage may result.
- Do not gaze into the LF1D/2D-FL illumination unit while it is lit, and do not project the light to other people, otherwise eyes may be injured.
- Make sure that the LF1D/2D-FL illumination unit does not fall during transportation, installation, and operation, otherwise damage may result.
- Install the LF1D/2D-FL illumination unit in places that have enough strength to support the weight of the unit.
- Do not pull out or push in the cable of the LF1D/2D-FL illumination unit, otherwise damage may result. Give a slack to the cable while wiring.
- Do not use or keep the LF1D/2D-FL illumination unit in a place where it is subjected to excessive vibrations or shocks, otherwise malfunction may result.
- Do not loosen screws, otherwise the protection characteristics will be impaired. Do not cover the LF1D/2D-FL illumination unit with inflammables such as paper, cloth and thermal insulation. Also, do not put something inflammable near the LF1D/2D-FL. These can cause fires and malfunction.
- The LF1D/2D-FL illumination unit is a general-purpose and industrial electronic device. Do not use the LF1D/2D-FL illumination unit for electronic equipment which may damage a human body or threaten a life in case a malfunction or failure occurs.
- Make sure that the cable does not touch the LF1D/2D-FL illumination unit housing.
- When using the LF1D/2D-FL illumination unit where it is subjected to dust, water, or oil, make sure to provided dustproof, waterproof, or oilproof treatment to the wiring parts,

CAUTION

- LED modules and illumination units may vary in illumination colors and illuminance.
- Apply a voltage within the rated value, otherwise the LED elements may be damaged.
- The LF1D/2D-FL illumination unit is vulnerable to static electricity. Take a sufficient measure for protection against static electricity and surge voltages.
- The LF1D/2D-FL illumination unit dose not have radiation resistance or ultraviolet rays resistance.
- Do not drop the LF1D/2D-FL illumination unit during moving or transportation. Also, do not apply external force to the unit. Do not leave the damaged illumination unit unrepaired.
- Make sure of the correct operating temperature, which is the temperature around the LF1D/2D-FL illumination unit. Otherwise internal temperature rise may result in damage.
- The LF1D/2D-FL illumination unit is not radiation- or ultraviolet-proof.
- Do not use the LF1D/2D-FL illumination unit in a place where it is subjected to:
 - Direct sunlight, near heaters, or high temperature
 - Corrosive/volatile/flammable gas, or chemicals
 - Basements, greenhouses, and humid places
 - Electric/magnetic field
 - Flammable substances
 - Outdoors
 - Saltwater
 - Cold storage warehouses or cooler exhaust outlets (make sure no freezing occurs)
 - Ozone, radiation, or ultraviolet rays
- Do not loosen screws, otherwise the protection characteristics will be impaired.

- The LF1D/2D-FL illumination unit is extremely hot for about 30 minutes after power-on. Be careful not to burn your hand.
- Clean the LF1D/2D-FL illumination unit when necessary, using a soft cloth slightly dampened with water or neutral detergent.
- Power off the unit immediately when any abnormality is found, and contact IDEC.

1 Types	
Shape	Type No.
Box	LF1D-FL2F-2W-A
Flange	LF1D-FL2F-2W-A

2 Specifications

General Specifications		
Type No.	LF1D-FL2F-2W-A	LF2D-FL2F-2W-A
Applicable Standard	EN61547 , EN55015	
Rated Voltage	24V DC (Operating voltage range: 21.6V to 26.4V DC)	
Input Current (approx.)	500 mA typ. (565 mA maximum)	
Rated Power (approx.)	12.0W typ. (13.6W maximum)	
Operating Temperature	-30 to +55°C (no freezing)	
Storage Temperature	-35 to +70°C (no freezing)	
Operating Humidity	45 to 85% RH (no condensation)	
Storage Humidity	20 to 90% RH (no condensation)	
Life *1	50,000 hours minimum (until the brightness reduces to 70% the initial value in 25°C and 45%RH environment)	
Insulation Resistance	1 MΩ minimum (500V DC megger)	
Dielectric Strength	1000V AC, 1minute (between input terminal and ground terminal or housing)	
Vibration Resistance (damage limits)	5 to 55Hz, amplitude 0.5 mm	
Shock Resistance (damage limits)	1000 m/s ²	
Material	Front Cover /Flange	Stainless / Diecast aluminium
	Housing:	Diecast aluminium
	Lens *2 :	einforced Glass Polycarbonate
	Cable Gland:	PA66
	Mounting Bracket:	Stainless
	Cable:	PVC
Weight (approx.)	1000g	1050g
Degree of Protection	IP67F※2	

- *1: Life of the LED is greatly affected by the operating conditions.
 *2: Water- and oil-tight characteristics are tested to IEC60529/DIN40050-9 requirements and do not assure protection against all actual operating conditions.

LED Optical Specifications	
Illumination Color	White
Color Temperature (typ.)	5700 K
Reference Illuminance (typ.) at 1.0m (perpendicular)	1300 lx

3 Installation

Wall and ceiling Surface Mount for LF1D Series Wall and ceiling Recessed Mount for LF2D Series

CAUTION

- Install the LF1D/2D-FL illumination unit in places that have enough strength to support the weight of the unit.
- Attach the clamp face for the grounded metal panel as static electricity and surge voltages.

Box

- Bracket Mount (see 4. Dimensions for mounting centers.)
- When using the rear screw holes (see "Note" of 4. Dimensions) Mount the LF1D-FL illumination unit using four M5 screws. Tighten the screws to thetorque shown below. Recommended tightening torque: 2.6 to 3.7 N·m

Flange

Mounting Centers (see Dimensions)
Mounting Prodedure

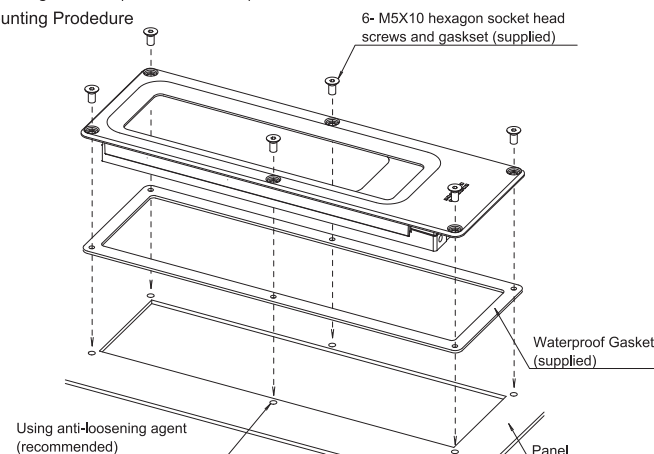

- Apply Loctite on the female threads in the panel to prevent the screws from loosening. Make sure that Loctite does not flow out of the threads. (Recommended: LOCTITE 425, ThreeBond 1401) Note: When not using Loctite, make sure that the screws are not loosened before starting operation of the illumination unit.
- Install the illumination unit on the panel using the hexagon socket head screws and waterproof gasket supplied with the illumination unit.

4 Dimensions

<Box>

LF1D-FL2F-2W-A

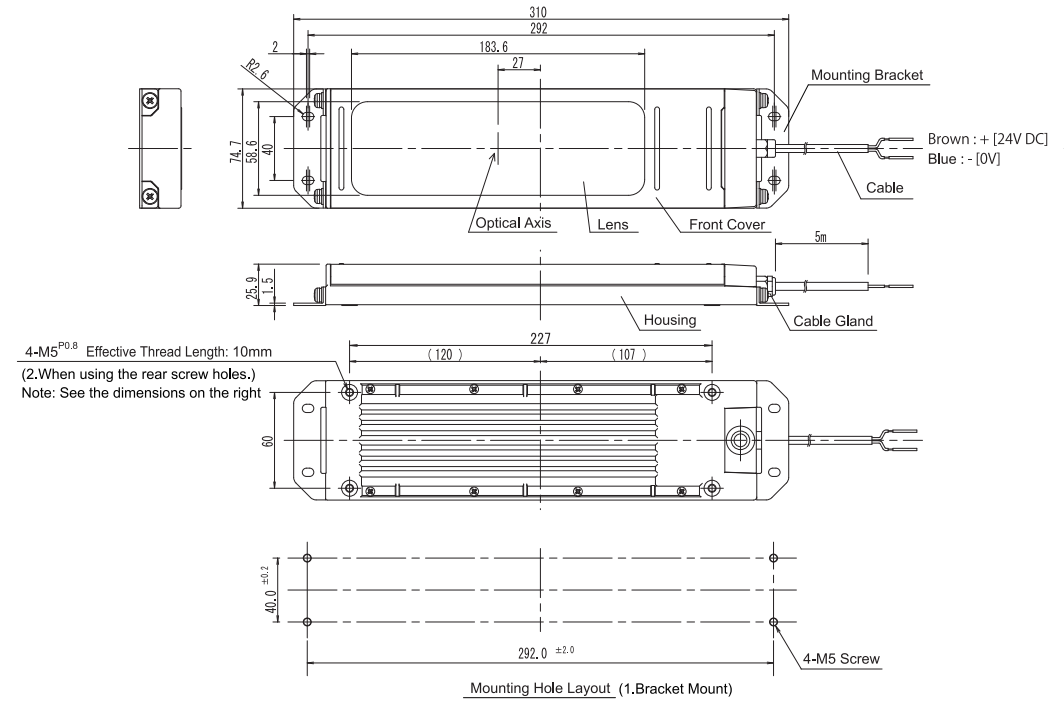

<Flange>

LF2D-FL2F-2W-A

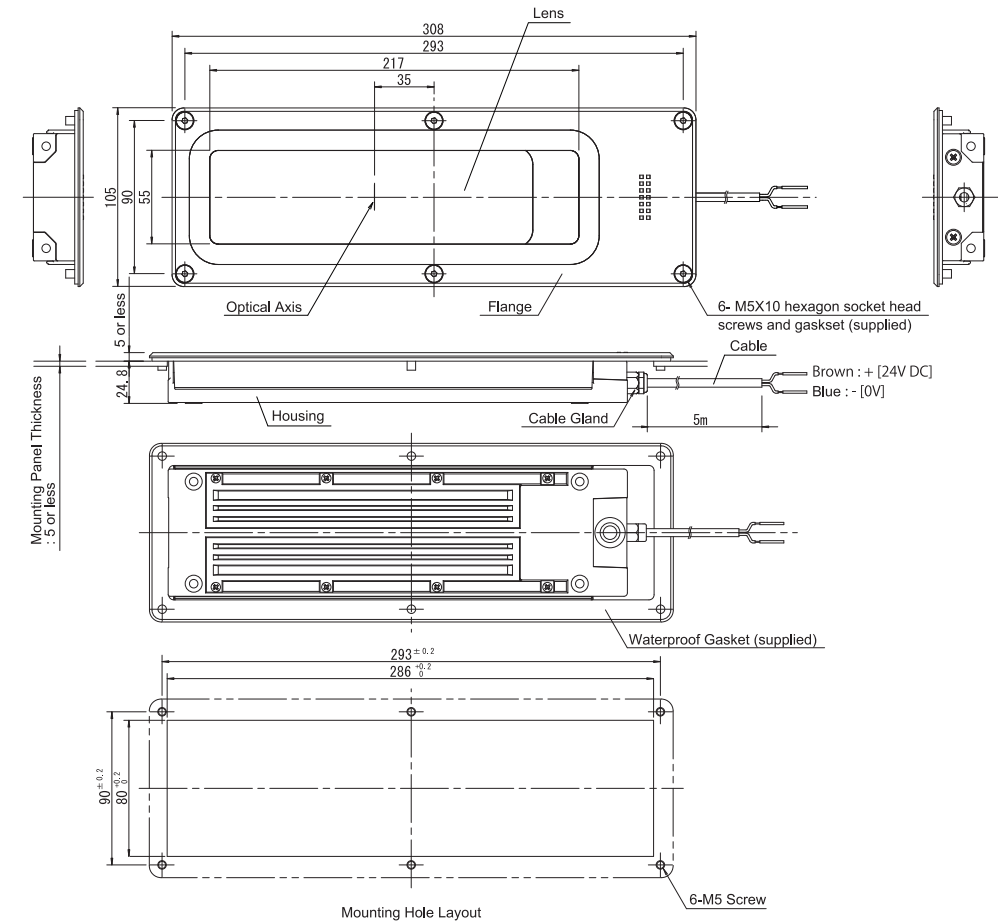

All dimensions in mm.

5 Precautions for Disposal

- Dispose of the LF1D/2D-FL illumination Unit as an industrial waste.

IDEC CORPORATION

Manufacturer : IDEC CORP.
 2-6-64 Nishimiyahara Yodogawa-ku, Osaka, 532-0004, Japan
 EU Authorized Representative : APEM SAS
 55, Avenue Edouard Herriot BP1, 82303 Caussade Cedex, France