

SA1F Time of Flight Laser Sensor

Quick Start Guide

Laser sensor with both analog discrete (switched) output.

This guide is designed to help you set up and install the SA1F Time of Flight Laser Sensor.

For complete information on programming, performance, troubleshooting, dimensions, and accessories, please refer to the Instruction Manual. Use of this document assumes familiarity with pertinent industry standards and practices.

	<p>WARNING: Not To Be Used for Personnel Protection Never use this device as a sensing device for personnel protection. Doing so could lead to serious injury or death.</p> <p>This device does not include the self-checking redundant circuitry necessary to allow its use in personnel safety applications. A sensor failure or malfunction can cause either an energized or de-energized sensor output condition.</p>
--	--

Features and Indicators

Three LED indicators provide ongoing indication of the sensing status.

Analog Output LED Indicator

Solid Amber: Displayed distance is within the taught analog output window

OFF: Displayed distance is outside the taught analog output window

Power LED Indicator

Solid Green: Normal operation, power ON and laser ON

Flashing Green (1Hz): Power ON and laser OFF (Laser enable Mode)

Discrete Output LED Indicator

Solid Amber: Discrete Output is ON

OFF: Discrete Output is OFF

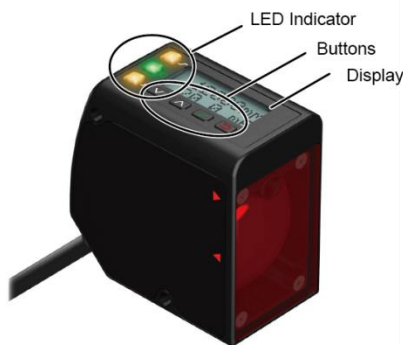

Figure1. Sensor Features

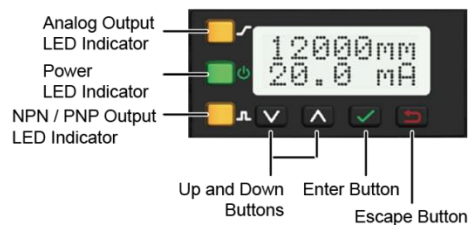

Figure2. LCD Display

Display

The display is a 2-line, 8-character LCD. The main screen is the *Run Mode* screen, which shows the real-time distance measurement and the analog output measurement..



Figure3. Display shown in Run Mode

Note: The display may differ from the actual distance due to operating environment, target and aging. The distance data is a reference value.

Buttons

Use the sensor buttons **Down**, **Up**, **Enter**, and **Escape** to program the sensor and to access sensor information.

Down and Up Buttons

Press **Down** and **Up** to:

- Access the *Quick Mode* from *Run Mode*
- Navigate the menu systems
- Change programming settings
- Change individual digit values in distance based settings

When navigating the menu systems, the menu items loop.

Enter Button

Press **Enter** to:

- Access the *Menu Mode* from *Run Mode*
- Access the submenus
- Move right one digit in distance based settings
- Save changes

In the *Menu Mode*, a check mark  in the lower right corner of the display indicates that pressing **Enter** accesses a submenu. Press **Enter** to save changes. New values flash rapidly and the sensor returns to the parent menu.

Escape Button

Press **Escape** to:

- Leave the current menu and return to the parent menu
- Return to *Run Mode* from the *Quick Mode*



Note: Pressing **Escape** discards any unsaved programming changes.

In the *Menu Mode*, a return arrow  in the upper left corner of the display indicates that pressing **Escape** returns to the parent menu. Press and hold **Escape** for 2 seconds to return to *Run Mode* from any menu or remote teach.

Laser Description and Safety Information



CAUTION: Use of controls or adjustments or performance of procedures other than those specified here in may result in hazardous radiation exposure. Do not attempt to disassemble this sensor for repair. A defective unit must be returned to the manufacturer.

Class 2 Laser Models



CAUTION: Never stare directly into the sensor lens. Laser light can damage your eyes. Avoid placing any mirror-like object in the beam. Never use a mirror as a retroreflective target.



For Safe Laser Use - Class 2 Lasers

- Do not stare at the laser.
- Do not point the laser at a person's eye.
- Mount open laser beam paths is not at the eye level.

Reference IEC 60825-1:2007, Section 8.2.

Class 2 Lasers

Class 2 lasers are lasers that emit visible radiation in the wavelength range from 400 to 700 nm, where eye protection is normally afforded by aversion responses, including the blink reflex. This reaction may be expected to provide adequate protection under reasonably foreseeable conditions of operation, including the use of optical instruments for intrabeam viewing.

Class 2 Laser Safety Notes

Low-power lasers are, by definition, incapable of causing eye injury within the duration of a blink (aversion response) of 0.25 seconds. They also must emit only visible wavelengths (400 to 700 nm).

Therefore, an ocular hazard may exist only if individuals overcome their natural aversion to bright light and stare directly into the laser beam.



Figure4. FDA warning label (Class2)

Installation



Note: Handle the sensor with care during installation and operation. Sensor windows soiled by fingerprints, dust, water, oil, etc. may create stray light that may degrade the peak performance of the sensor. Blow the window clear using filtered, compressed air, then clean as necessary using 70% isopropyl alcohol and cotton swabs or water and a soft cloth.

Mount the Sensor

1. Mount the sensor to the machine or equipment at the desired location.
2. Check the sensor alignment, Tighten the mounting screws to secure the sensor in the aligned position. If a bracket is needed, mount the sensor onto the bracket (sold separately).

Wiring Diagrams

Analog Current Models

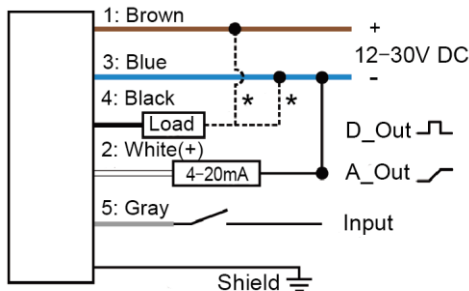

*User-configurable NPN/PNP setting

Analog Voltage Models

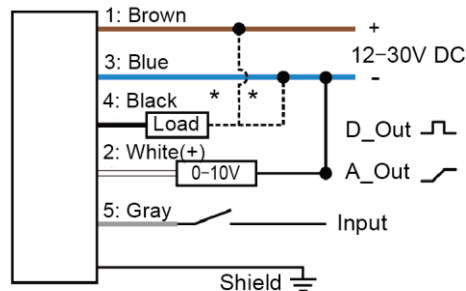

*User-configurable NPN/PNP setting

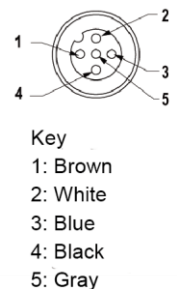

Sensor Programming

Program the sensor using the buttons on the sensor or the remote input (limited programming options).

From *Run Mode*, use the buttons to access the *Quick Mode* and the *Menu Mode*. See *Quick Mode* on page 4, *Menu Mode (MENU)* on page 4, for more information on the options available from each menu. For TEACH options, follow the TEACH instructions in the instruction manual.

In addition to programming the sensor, use the remote input to disable the buttons for security, preventing unauthorized or accidental programming changes.

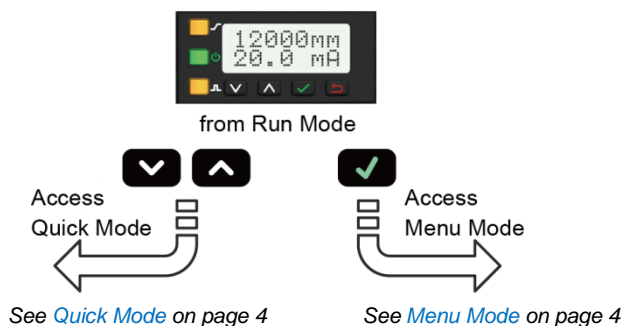

Figure5. Accessing the Menus

Quick Mode

The sensor includes a *Quick Mode* with easy access to view and change the analog and discrete output switch points. Access the *Quick Mode* by pressing **Down** (v) or **Up** (^) from *Run Mode*. When in the *Quick Mode*, the current distance measurement displays on the first line and the menu name and the analog value alternate on the second line of the display. Press **Enter** (✓) to access the switch points. Press **Down** and **Up** to change each digit. Press **Enter** to move right one digit. After reviewing each digit, press **Enter** again to save the new value and return to the *Quick Mode*. Press **Cancel** to ignore any changes made if only some digits have been changed.

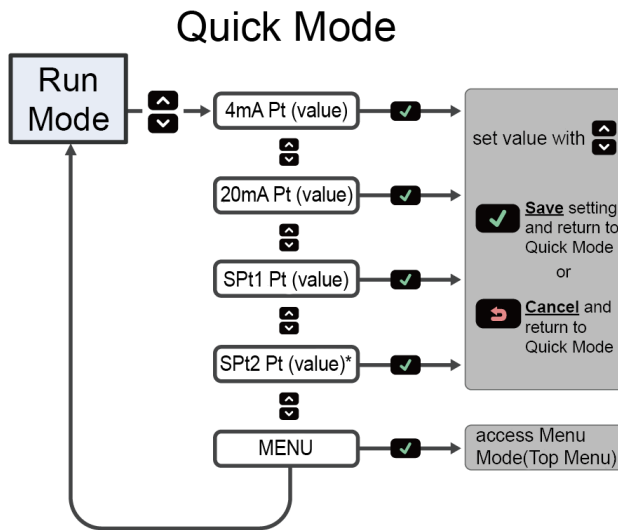

Figure6. Quick Mode Map (Window Mode)

*: In Setpoint Mode, [SPt1 Pt] is replaced by [SPt] and [SPt2 Pt] is not available.

Menu Mode (MENU)

Access the *Menu Mode* by pressing **Enter** from *Run Mode*. The *Menu Mode* is also accessible from the *Quick Mode*: navigate to **MENU** and press **Enter** . The *Menu Mode* includes several submenus that provide access to view and change sensor settings and to view sensor information.

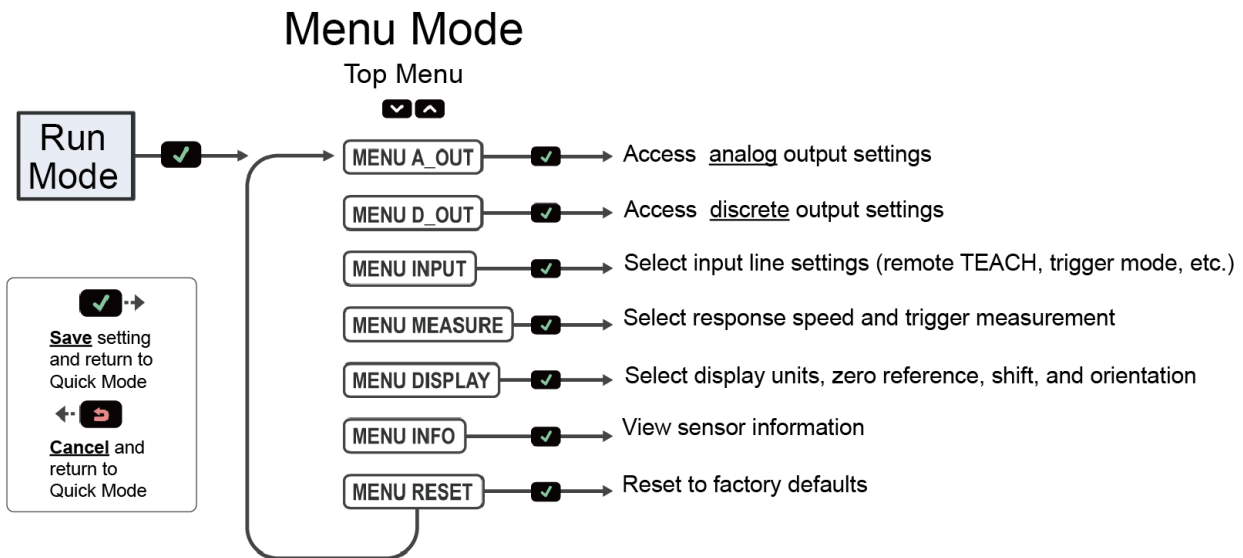

Figure7. Menu Mode Map (Top MENU)

Menu Mode Map

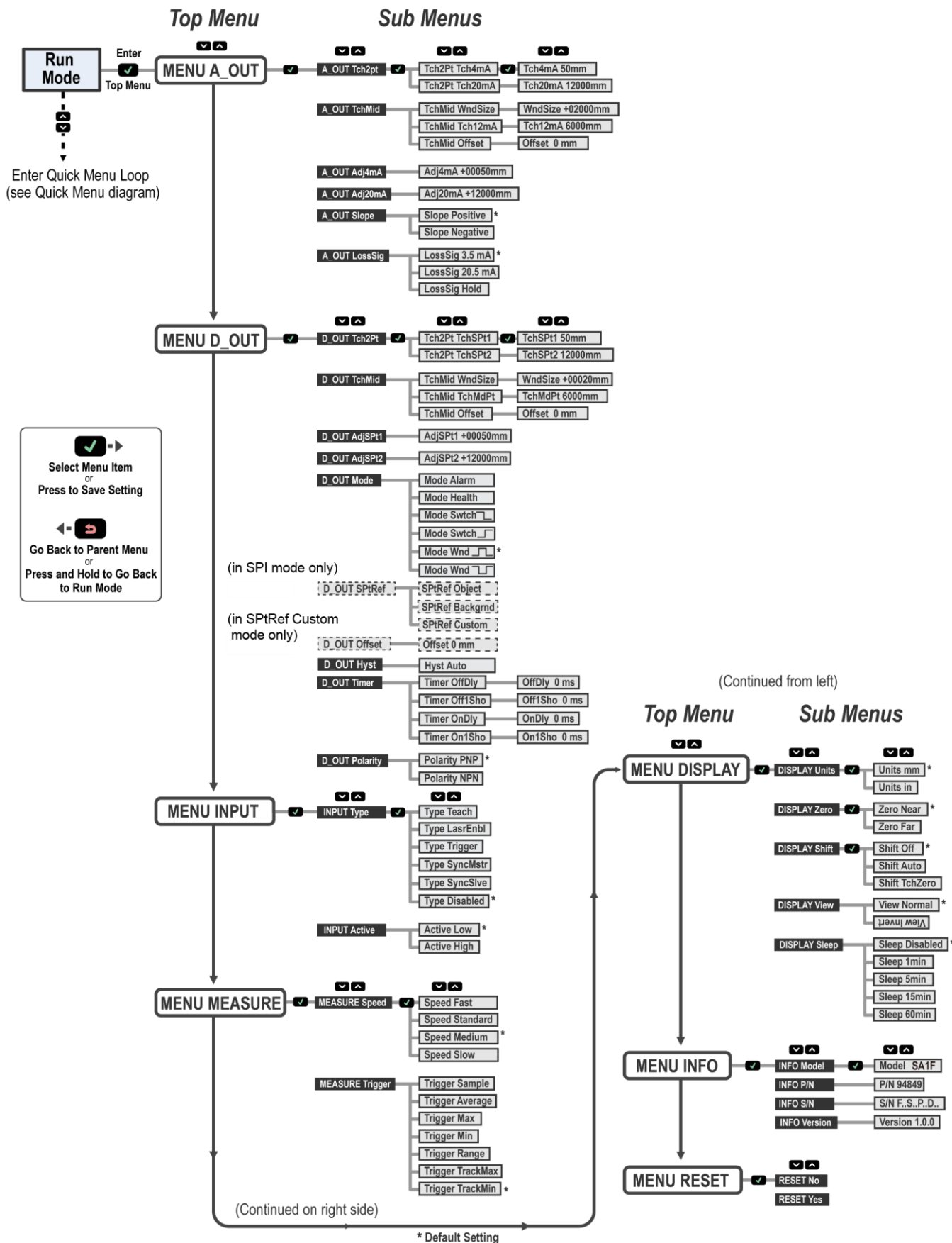

Figure8. Menu Mode Map

Specifications

Sensing Beam

Visible red Class 2 laser, 660 nm

Supply Voltage (Vcc)

12 to 30 V DC

Power and Current Consumption, exclusive of load

Normal Run Mode: <2.4W

Current consumption < 100mA at 24V DC

Supply Protection Circuitry

Protected against reverse polarity

Construction

Die-cast zinc housing; acrylic window, polycarbonate LED, aluminum side plate

Maximum Tightening Torque

2.6 N · m

Output Configuration

Analog output: 4 to 20mA or 0 to 10V, depending on model
Discrete output rating: Discrete NPN/PNP is user-configurable

Output Rating

Discrete Output: 100 mA maximum
(protected against continuous overload and short circuit)

OFF-state leakage current (PNP): < 40 µA at 30V

OFF-state leakage current (NPN): < 200 µA at 30V

Output saturation (PNP outputs): < 3V at 100mA

Output saturation (NPN outputs): < 1.6V at 100mA

Analog current output (SA1F-*A): 1kΩ maximum at 24V

maximum load resistance: [(Vcc-4.5) / 0.02Ω]

Analog Voltage output (SA1F-*V): 2.5kΩ minimum load resistance

Remote Input

Allowable Input Voltage Range: 0 to Vcc

Active Low:

High State > 4.3V at 740mA maximum

Low State < 1.3V at 800mA maximum

Active High:

High State > 4.3V at 1.7mA maximum

Low State < 1.3V at 1.6mA maximum

Repeatability

See Performance Curves on page 7 and 8.

Response Speed

Menu	Response Speed
Fast	1.5ms
Standard	8ms
Medium	32ms
Slow	256ms

Sensing Range at Slow Speed

• SA1F-12*:

90% White Target: 50 to 12,000 mm

18% Gray Target: 50 to 11,000 mm

6% Black Target: 50 to 7,000 mm

• SA1F-24* :

90% White Target: 50 to 24,000 mm

18% Gray Target: 50 to 18,000 mm

6% Black Target: 50 to 11,000mm

Note:

When using at 100mm or less, it may not display correctly.

Ambient Light Immunity

< 40,000 lux

Note:

If Ambient Light Immunity is bright, the detection distance may change.

Delay at Power Up

2 seconds

Measurement Output Rate

0.5ms

Minimum Window Size, Analog and Discrete

10mm

Boresighting

80 mm radius at 12,000 mm

160 mm radius at 24,000 mm

Temperature Effect

50 to 12,000mm: ±0.5mm/ °C (typical)

>12,000mm: ±1.0mm/ °C (typical)

Linearity/Accuracy

• SA1F-12*

Reflectance	±50mm
6% Black Card	7m
18% Gray Card	11m
90% White Card	12m

• SA1F-24*

Reflectance	±50mm	±75mm	±100mm	±200mm
6% Black Card	7m	-	9m	11m
18% Gray Card	11m	-	14m	18m
90% White Card	20m	24m	-	-

Beam Spot Size

Distance	Spot Size
50mm	6.5mm
7,500mm	10mm
12,000mm	12.5mm
24,000mm	35mm

Beam spot size is calculated as 1.6 times the D4σ measured diameter.

Storage Conditions

-30 to +65 °C

Operating Conditions

-20 to +55°C

90% at +55°C maximum relative humidity (non-condensing)

Degree of Protection

IEC IP67

Vibration and Shock Resistance

IEC 60947-5-2.

Application Note

- For optimum performance, allow 15 minutes for the sensor to warm up.
- Since the detection distance may change due to the surrounding environment or aging, please perform correction and maintenance on a regular basis.
- In an operating environment with a temperature change, please set the sensor with sufficient margin.
- After the SA1F housing, when transporting or storing under high temperature environment, please reconfirm the sensing range at startup.
- Depending on the use environment, the housing may be discolored, but performance of the sensor is not affected.
- When handling, take measures against static electricity and surges.
- If the power supply voltage is not stable, malfunction may occur.

Certifications



Class 2 power

UL Environmental Rating: Type 1

Required Overcurrent Protection

	<p>WARNING: Electrical connections must be made by qualified personnel in accordance with local and national electrical codes and regulations.</p>
---	---

Overcurrent protection is required to be provided by end product application per the supplied table.

Overcurrent protection may be provided with external fusing or via Current Limiting, Class 2 Power Supply. Supply wiring leads < 24 AWG shall not be spliced.

Repeatability Performance

SA1F-12✳

• Speed: Fast (1.5ms)

• Speed: Medium (32ms)

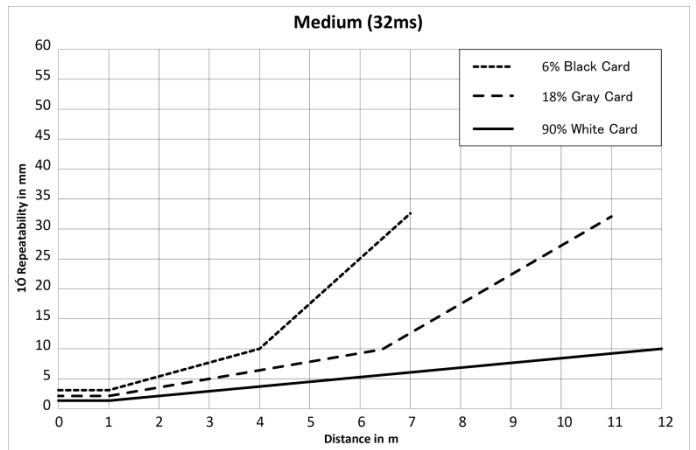
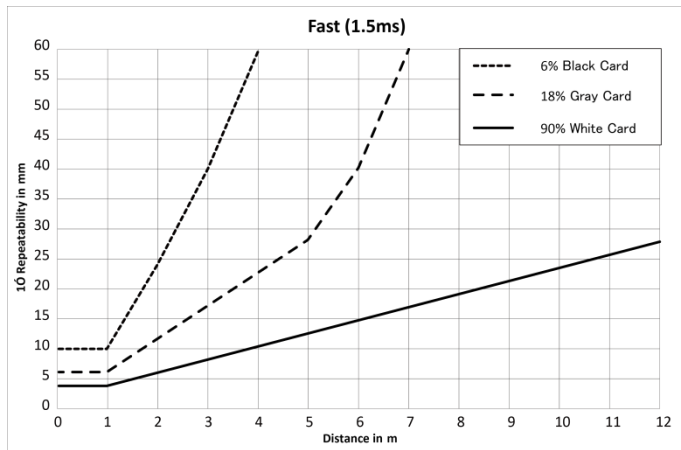

• Speed: Standard (8ms)

• Speed: Slow (256ms)

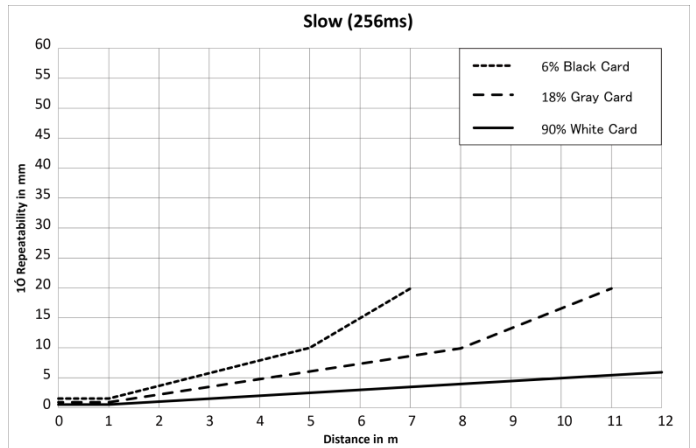
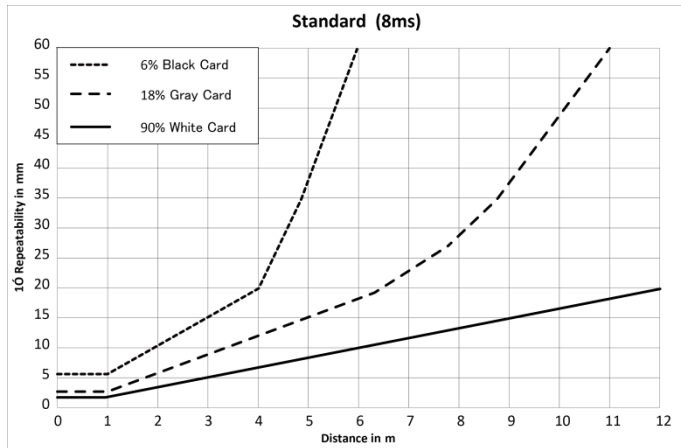

SA1F-24✳

• Speed: Fast (1.5ms)

• Speed: Medium (32ms)

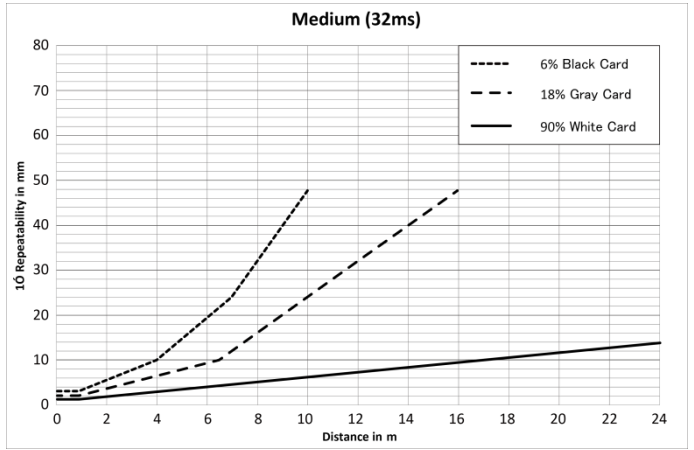
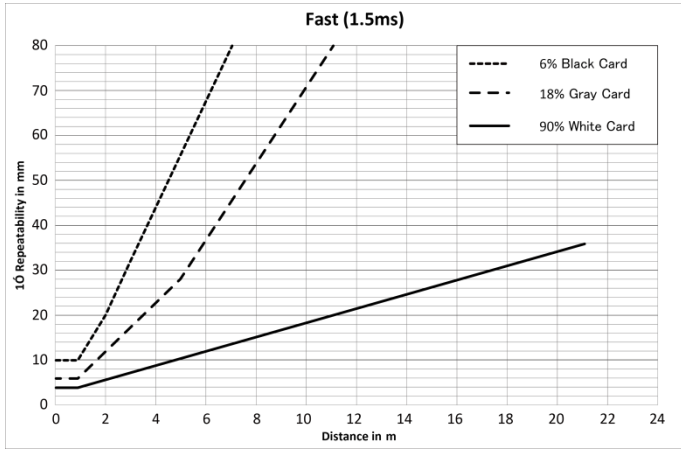

• Speed: Standard (8ms)

• Speed: Slow (256ms)

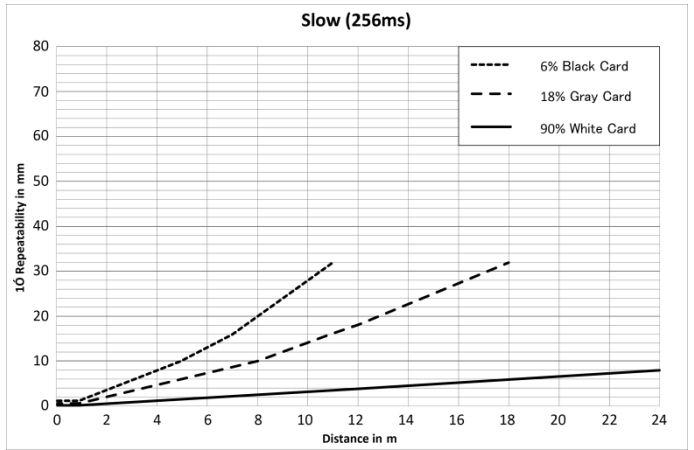
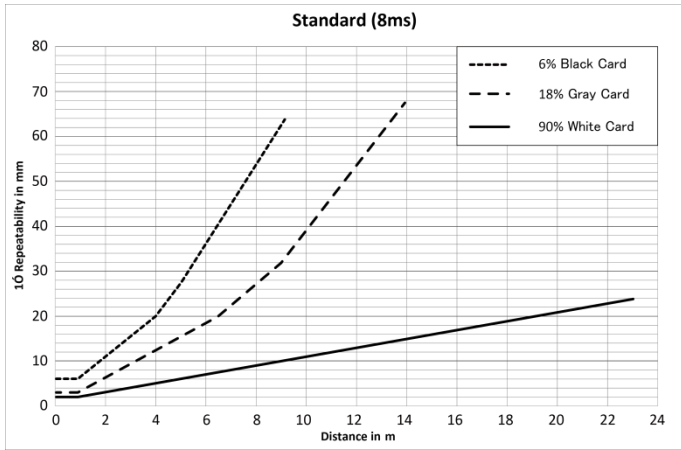

Dimensions

All dimensions in mm.

• Type M12 Connector

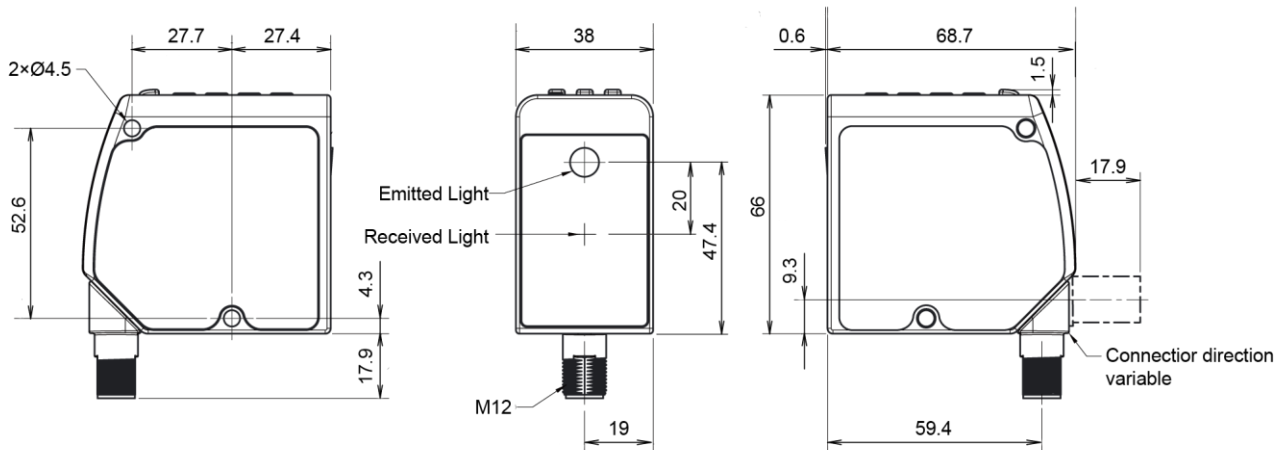

• Type Cable

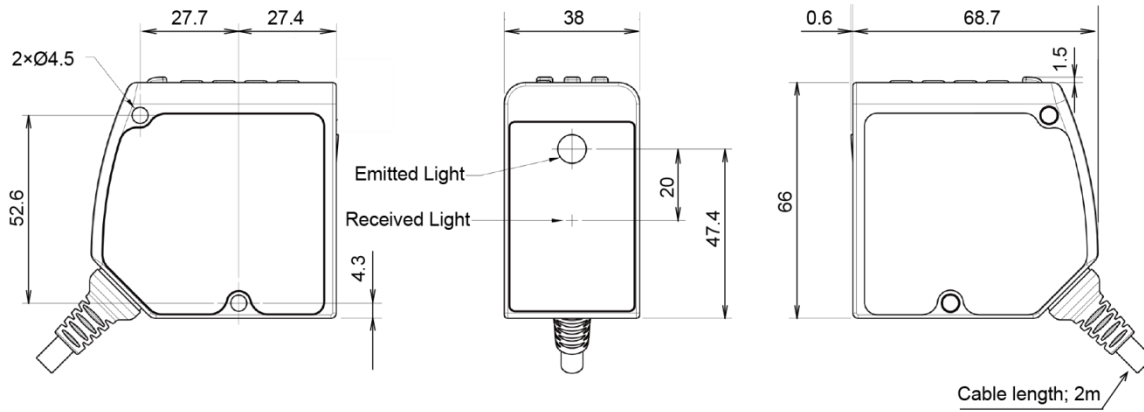

Accessories

• Shielded, 5-pin threaded M12 Cable

Appearance	Type No.	cable length	Type	Degree of Protection
	SA9Z-B2M67S	2m	straight	IP67
	SA9Z-B2ML67S		Right-Angle	
	SA9Z-B5M67S	5m	straight	
	SA9Z-B5ML67S		Right-Angle	
	SA9Z-B9M67S	9m	straight	
	SA9Z-B9ML67S		Right-Angle	
	SA9Z-B15M67S	15m	straight	
	SA9Z-B15ML67S		Right-Angle	

• Brackets

Type No.	Type
SA9Z-B01F	Adjustable
SA9Z-B02F	Right-Angle

Dimensions

All dimensions in mm.

• SA9Z-B□M67S

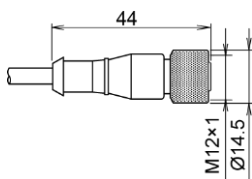

• SA9Z-B□ML67S

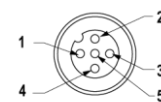
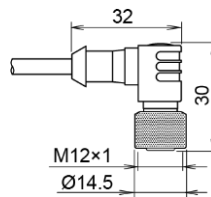

- Key
 1: Brown
 2: White
 3: Blue
 4: Black
 5: Gray

• SA9Z-B01F

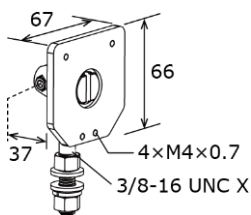

• SA9Z-B02F

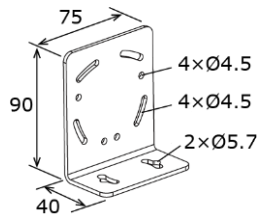

IDEC Warranty

IDEC warrants its merchandise to be free from defects in material and workmanship under normal and proper use for a Period of one (1) year from date of shipment. Buyer's exclusive remedy for a non conformity in any item shall be repair or Replacement at seller's option. This warranty is in lieu of all other warranties whether expressed, implied or statutory, including implied warranties of merchantability and of fitness. IDEC shall not be liable for claims based on breach of warranty or negligence or any other damages including consequential, contingent or incidental damages. Warranty does not apply if the merchandise is altered or modified in any way after delivery by IDEC.

Exclusion

- The SA1F is for general electronic equipment. Do not use SA1F for the purpose that malfunction or failure may directly threaten the human body and life.
- The SA1F is not intended to be used for applications which require high reliability and safety, such as medical equipment, nuclear equipment, railways, aircraft, and vehicles. The SA1F cannot be used for these applications.
- Use the product within the environmental limits given in the Catalog and Quick Start Guide.

IDEC CORPORATION

Manufacturer : IDEC CORPORATION,
2-6-64 Nishimiyahara, Yodogawa-Ku, Osaka 532-0004, Japan
EU Authorized Representative : APEM SAS
55, Avenue Edouard Herriot BP1, 82303 Caussade Cedex, France

<http://www.idec.com>