

INSTRUCTION SHEET



HS1C-P Interlock Plug Unit with Door Lock

Confirm that the delivered product is what you have ordered. Read this instruction sheet to make sure of correct operation. Make sure that the instruction sheet is kept by the end user.

SAFETY NOTE

CAUTION

Caution notices are used where inattention might cause personal injury or damage to equipment.

1 Type

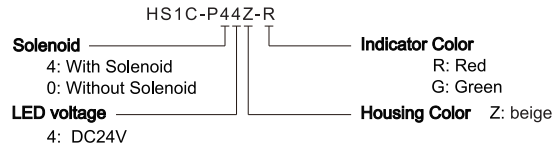

2 Specifications and Ratings

Applicable Standards	Main Circuit	UL498, CSA C22.2 No.182.1
	Auxiliary Circuit	UL508, CSA C22.2 No.14
	Standards for Use	EN1088
Operating Condition	Operating Temperature	-25 to +50°C (no freezing)
	Operating Humidity	45 to 85% (no condensation)
	Storage Temperature	-40 to +80°C (no freezing)
	Pollution Degree	3
Insulation Resistance		100 MΩ minimum (DC500V megger)
Contact Resistance		100 mΩ maximum (Initial value)
Dielectric Strength		Between live and dead parts: 2000V, 1 minute
		Between terminals of the same pole: 1000V, 1 minute
Shock Resistance		Damage limits: 1000m/s ²
Vibration Resistance		Operating extremes: 10 to 55 Hz, half amplitude 0.5 mm
		Damage limits: 30 Hz, half amplitude 1.5 mm
Operating Frequency		900 operations/hour (Actuator and Plug)
Actuator Operating Speed		0.05 to 1.0 m/s
Actuator Tensile Strength when Locked		1500 N minimum
Direct Opening Travel		11 mm minimum
Direct Opening Force		10 N minimum
Plug Strength When Locked		Rotation Strength: 5N · m minimum
		Tensile Strength: 500 N minimum
Mechanical Life		30,000 operations minimum (Actuator and Plug)
Solenoid	Rated Operating Voltage	24VDC 100%ED
	Rated Current	260mA
	Coil Resistance	95Ω (at 20°C)
	Turn ON Voltage	Rated Voltage × 90% maximum (at 20°C)
	Turn OFF Voltage	Rated Voltage × 10% minimum (at 20°C)
	Rated Power Consumption	Approx. 6.3W
Pilot light	Rated Operating Voltage	24VDC
	Rated Current	10mA
	Light Source	LED lamp
	Lens Color	R(Red), G(Green)
Weight		Approx. 720 g (HS1C-P44Z-□)

Type	HS1C-P44Z	HS1C-P04Z	
Main Circuit *	Rated insulation voltage (Ui)	250V	250V
	Thermal current (Ith)	10A	10A
Auxiliary Circuit	Rated insulation voltage (Ui)	250V	250V
	Thermal current (Ith)	3A	3A
	Rated Operating Voltage (Ue)	250V	250V
	Rated Operating current (Ie)	0.1A (AC250V · DC30V) (resistive load)	3A (AC250V · DC30V) (resistive load)

*: Main circuit is disconnecting use plug only

3 Mounting

- Mount the interlock plug unit on the equipment body.
- Mount the actuator on the door.
- See the figure below.

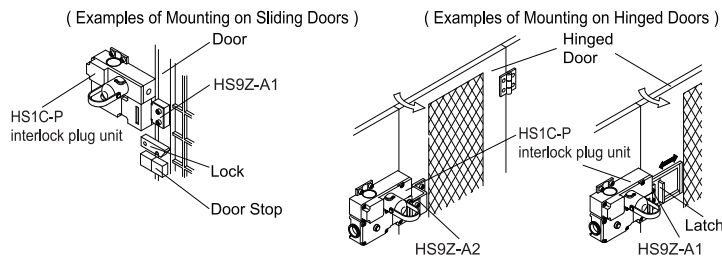

4 Notes for Operation

Installation

- The plug of HS1C-P interlock plug unit resemble the plug of HS2P interlock plug unit, however, these plugs are not interchangeable. Do not use the plugs of other types, otherwise the interlock plug units will be damaged. The plugs can be distinguished with the handle color.
HS1C-P: black
HS2P: aluminum color
- Regardless of door types, do not use the interlock plug unit as a door stop. Install a mechanical door stop at the end of the door to protect the interlock plug unit against an excessive force. If excessive force is applied to the plug, especially to the direction of removing the plug, solenoid operation failure may occur even though the solenoid is energized, resulting in unlocking failure.
- Do not apply an excessive shock to the interlock plug unit when opening or closing the door. A shock to the interlock plug unit exceeding 1,000 m/s² may cause failure.
- Regardless of door types, do not use the interlock plug unit as a door lock. Install a separated lock as shown in item 3.
- When opening the interlock plug unit lid to wire, open the lid ① only. (See the figure on the right.) Never remove other screws, otherwise the interlock plug unit may be damaged.
- The interlock plug unit cover can be only removed or installed with the special L-shaped wrench supplied with the interlock plug unit.
- Avoid foreign objects such as dust, liquid and oil from entering the interlock plug unit while connecting a conduit or wiring.
- Entry of foreign objects in the actuator entry slot may affect the mechanism of the interlock plug unit and cause a breakdown. If the operating atmosphere is contaminated, use a protective cover to prevent the entry of foreign objects into the interlock plug unit through the actuator entry slots.
- Avoid foreign objects such as dust, liquid and oil from entering the interlock plug unit while connecting a conduit or wiring.
- Use only the designated actuator for the HS1C-P. Other actuators will cause a breakdown of the interlock plug unit.
- Do not store the interlock plug units in a dusty, humid, or organic-gas atmosphere. Also avoid direct sunlight.

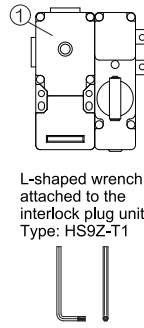

CAUTION

- Turn off the power to the interlock plug unit before starting installation, removal, wiring, maintenance, and inspection on the interlock plug unit. Failure to turn power off may cause electrical shocks or fire hazard.
- Use wires of a proper size to meet voltage and current requirements. Tighten the terminal screws to a recommended tightening torque. Loose terminal screws will cause unexpected heating and fire hazard during operation.
- Do not install the actuator in the location where the human body may come into contact. Otherwise injury may occur.
- Pay attention to the management of spare actuator. Safety function of interlock plug unit will be lost in case the spare actuator is inserted into the interlock plug unit.
- Ensure that the actuator is firmly fastened to the door (welding, rivet, special screw) in the appropriate location, so that the actuator cannot be removed easily.
- Do not disassemble or modify the interlock plug unit. Also do not disable the function of interlock plug unit intentionally. Otherwise a malfunction or an accident may occur.
- Do not install the interlock plug unit in places subject to oil or water. Electric shocks or fire hazard may be caused if the interlock plug is operated when the plug part is contaminated with oil or water.
- Interlock plug units are used to ensure the safety of operators who carry the plugs. Provide only one plug to a guard. Otherwise the hostage control function is lost, endangering the operators. Ensure complete safety management so that the function is maintained.
- Make sure that the interlock plug unit is not energized when removing or installing the plug (after operating the emergency stop button shown in the circuit example shown on the right). Do not start or stop the machine by plug removal/ installation, otherwise the interlock plug unit may fail.
When using the main circuit on AC, connect the emergency stop switch to Line, and the interlock plug unit to Neutral.

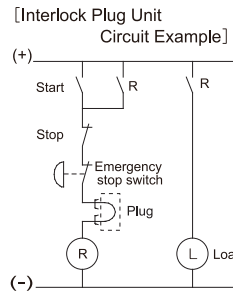

Manual Unlocking (with solenoid type only)

- The plug can be unlocked manually to check for secure mounting of the interlock plug unit before wiring or supplying power and remove the plug in an emergency such as power failure. (Unlocking Method)
① Remove the screw from the front of the interlock plug unit. Push the lever inside the interlock plug unit towards shown on the right using a small screwdriver until the plug is unlocked.
② Turn and remove the plug.
③ After the unlocking operation, ensure to turn the screw.

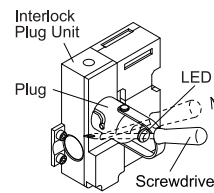

CAUTION

- Before manually unlocking the interlock plug unit, make sure the machine has come to a complete stop. Manual unlocking during operation may unlock the interlock plug unit before the machine stops, and the function of interlock plug unit is lost.

5 Adjustments

Actuator Mounting Reference Position

- As shown below, the mounting reference position of the actuator inserted into the interlock plug unit is the actuator cover or stop film touches the interlock plug unit lightly. (After mounting the actuator, remove the actuator cover or stop film from the actuator.)

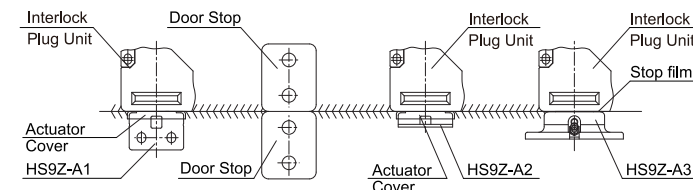

Minimum Radius of Hinged Door

When using the interlock plug unit for a hinged door, the minimum radius of the applicable door is shown in the following figures.

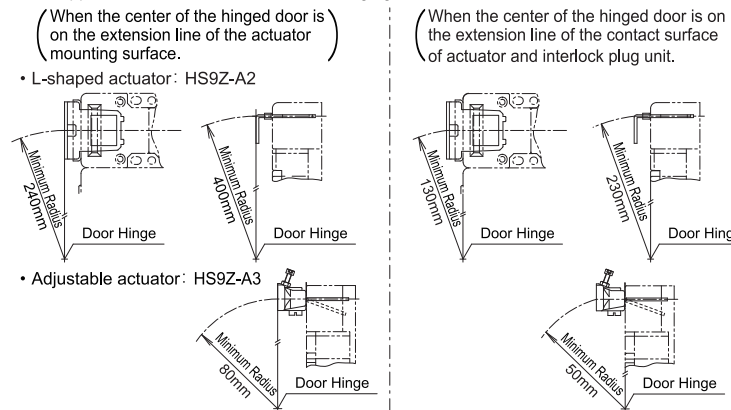

Note: The figures shown above are based on the condition that the actuator enters and exits the actuator entry slot smoothly when the door is closed or opened. Since there may be deviation or dislocation of the hinged door, make sure of correct operation in the actual application before installation.

Actuator Mounting Tolerance

- Mounting tolerance of the actuator is 1.0mm from the center of the actuator to up, down, right, and, left.
±1.0mm
- Actuator can move 3.8mm (HS9Z-A1S and -A2S)/ 2.7mm (HS9Z-A3S) from the mounting reference position without affecting the contact operation.
±1.0mm
- When closing the door, the actuator is inserted and locked within approx. 6.4mm (HS9Z-A1S and -A2S)/ 5.3mm (HS9Z-A3S) from the mounting reference position.

Recommended Screw Tightening Torque

	Screw Tightening Torque
For mounting the interlock plug unit (M5 Hexagon Socket Head Screw) *1	4.5 to 5.5 N · m
For mounting the actuator (M6 Hexagon Socket Head Screw) *1	4.5 to 5.5 N · m
For mounting the lid (M4)	1.1 to 1.3 N · m
Connector (G1/2)	2.7 to 3.3 N · m
Plug for Unused Conduit Hole (G1/2)	1.8 to 2.2 N · m
Screw Terminal No.1 to 6(M3)	0.4 to 0.6 N · m
Screw Terminal No.7,8(M3.5)	0.9 to 1.1 N · m
Ground Terminal screw (M4)	0.9 to 1.1 N · m
Angle adjusting screw of the adjustable actuator (M3 Hexagon Socket Head Screw)	0.8 N · m

*1: The recommended tightening torques of the mounting screw are the values confirmed with hex socket head bolts. When other screws are used and tightened to a smaller torque, make sure that the screws do not become loose after mounting.

Adjusting the Angle Adjustable Actuator

- Using the angle adjusting screw (M3 hexagon socket head screw), the actuator angle can be adjusted up to 20°.
- The larger the actuator angle, the smaller the applicable radius of the door swing. After installing the actuator, open the door. Then adjust the actuator angle so that the actuator enters the entry slot of the interlock plug unit properly.
- After adjusting the actuator angle, apply loctite or the like on the adjusting screw to prevent loosening.

6 Wiring

Circuit Configuration (Actuator: Installed, Plug: Installed, Solenoid: Off)

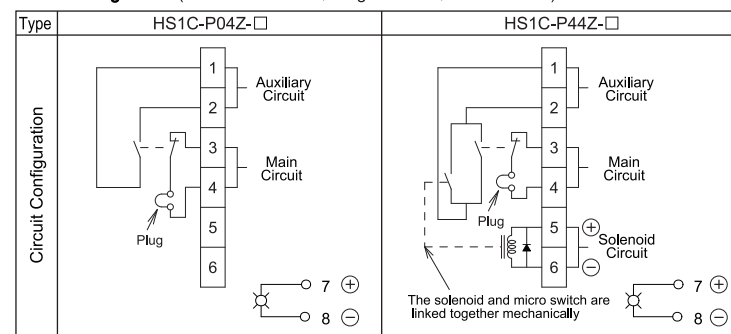

Operation Cycle

Interlock plug unit Operation Cycle	Type: HS1C-P44Z-□							
	Door Plug	Closed Installed	Closed Installed	Closed Removed	Open Removed	Open Removed	Open Removed	Closed Removed
Main Circuit	3-4	Closed	Closed	Open	Open	Open	Open	Open
Auxiliary Circuit	1-2	Open	Closed	Closed	Closed	Closed	Closed	Closed
Solenoid Power	5-6	Off	On	On	Off	Off	Off	Off
		Door is locked. Plug is locked. The machine can be operated.	Door is locked. Plug is unlocked. The machine can be operated.	Door is unlocked. The machine can not be operated.	Door is unlocked. The machine can not be operated.	Door is unlocked. The machine can not be operated.	Door is unlocked. The machine can not be operated.	Door is unlocked. The machine can not be operated.

Type: HS1C-P04Z-□

Interlock plug unit Operation Cycle	Door Plug	Closed Installed	Closed Removed	Open Removed
Main Circuit	3-4	Closed	Open	Open
Auxiliary Circuit	1-2	Open	Open	Closed
		Door is locked. Plug is unlocked. The machine can be operated.	Door is unlocked. The machine can not be operated.	Door is unlocked. The machine can not be operated.

Wire Length inside the Interlock Switch

Screw Terminal No.	Through Conduit Port (G1/2)	
	①	②
1	30±2	45±2
2	30±2	50±2
3	25±2	55±2
4	25±2	60±2
5	30±2	65±2
6	30±2	70±2
7	65±2	35±2
8	65±2	110±2
E	85±2	45±2

Wire Stripping Length: L2(mm) 7 ± 1

Recommended Wire Core Size

Screw Terminal No.1, 2, 5, 6, 7, 8 : 0.5 to 0.75 mm²
Screw Terminal No.3, 4, E : 1.0 to 1.25 mm²

Applicable Crimping Terminal

Screw Terminal No. 7, 8: Terminal Screw (M3.5)
Screw Terminal No. E: Ground Terminal Screw (M4)

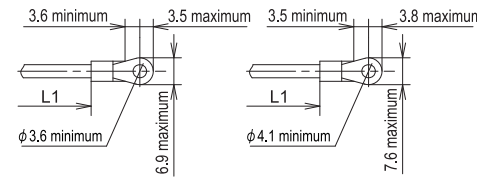

Screw Terminal No. 1 to 6 : Direct Wiring Using a solid or stranded wire
Note: When using a stranded wire, make sure that adjoining terminals are not short-circuited with protruding core wires. Also, do not solder the core wires to avoid protruding wires.

<Ferrules> : Recommended ferrules

Applicable wire (stranded) mm ²	AWG	Part No.
0.75	18	S3TL-H075-14WW
1	17	S3TL-H10-14WY
1.5	16	S3TL-H15-14WR

• Recommendation tools (sold separately)

Name	Part No.	Note
Crimping tool	S3TL-CR06D	Overseas limited sale

Applicable Connectors

- Use a connector with a degree of protection IP67.
- Applicable connector dimensions: See the figure on the right.
- When using plastic connector, metal connector and multi-core cable
Applicable Plastic Connector Example: Type SCS-10□ (made by Seiwa Electric)
Applicable Metal Connector Example: Type C20G-□□16 (made by SANKEI MANUFACTURING)
- Note: Confirm the outside diameter of the multi-core cable, the connector type depends on the outside diameter of multi-core cable.

7 Dimensions

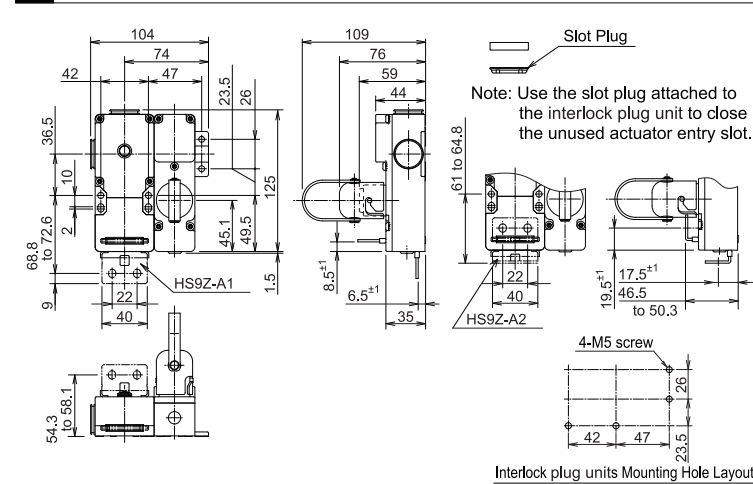

8 Precaution for Disposal

Dispose of HS1C-P interlock plug unit as an industrial waste.