

Short-body pilot lights

Ø22 HW Series



Short-body, compact design ideal for downsizing power distribution panels and control panels



• See website for details on approvals and standards.

Integrated terminal cover

Prevents short-circuit with an adjacent pilot light. The integrated terminal cover prevents the terminal cover from getting lost.

Space-saving

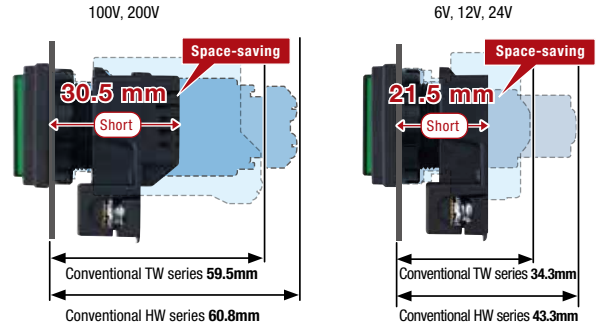

Downsized by **1/2** (Compared to conventional products)

ISO3864-4 Safety color compliant

Safety colors are defined by ISO standards. The bright and clear colors are suited for emergency situations.

First in the industry! Six different colors with a single LED (LSRD lamp)

Previously, 5 different color LEDs were required but with the new illuminated unit, only a single LED is used. Only the lens needs to be replaced to change the illumination color. The new LED reduces maintenance time, makes stock control easier, and is environmentally friendly.

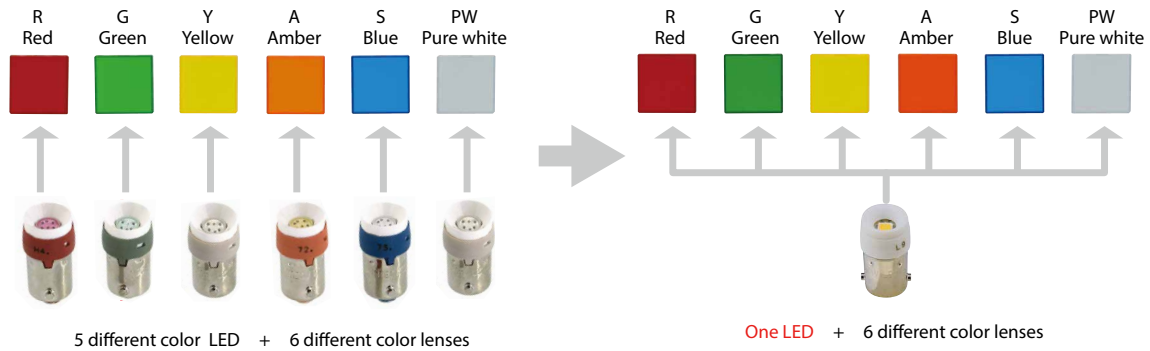

High visibility with new LEDs (LSRD lamp)

Brighter and clearer compared to conventional LEDs.

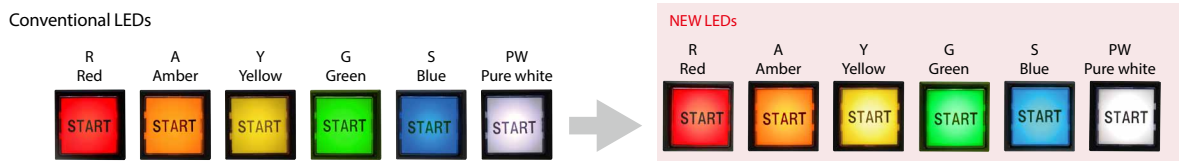

ø22 HW Series Short-Body Pilot Lights

Short-body 100V AC/DC and 200V AC types with a panel depth of 30.5 mm.
6V, 12V, and 24V AC/DC types are also available with a panel depth of 21.5mm.

Specifications

Operating conditions		Operating temperature: -25 to +50°C (no freezing) Storage temperature: -40 to +80°C (no freezing) Operating humidity: 45-85% (no condensation)
Insulation resistance		100MΩ min. (500V DC megger)
Overvoltage category		II
Impulse withstand voltage		2.5kV
Degree of pollution		3
Dielectric strength		Between live and dead metal parts: 2000V AC, 1 minute
Vibration resistance	Operating extremes	Vibration: 5 to 55Hz, amplitude 0.5mm
	Damage limits	Vibration: 5 to 55Hz, amplitude 0.5mm
Shock resistance	Operating extremes	100m/s ²
	Damage limits	1000m/s ²
Degree of Protection		Panel front: IP65 (IEC 60529)
Terminal style		M3.5 screw terminal
Terminal screw tightening torque		1.0 to 1.3N·m
Locking ring tightening torque		2.0N·m
Connectable wire		2mm ² max. (single wire ø 1.6 max.) 2 wires max.
Weight (approx.)		26g (HW□P-□JQ) 29g (HW□P-JRH2 / HW□P-JCM2)



Mounting hole layout / Minimum mounting centers

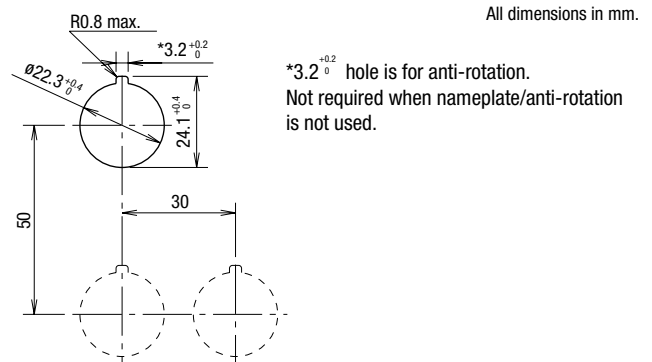

LED ratings

Rated voltage	6V AC/DC	12V AC/DC	24V AC/DC	100/110V AC/DC	200/220V AC 50/60Hz sine wave
Coil voltage range	6V AC/DC±10%	12V AC/DC±10%	24V AC/DC±10%	100/110V AC/DC±10%	200/220V AC±10%
Current draw	DC rating	10mA	7mA	7mA	10mA
	AC rating	14mA	8mA	8mA	11mA
Built-in LED part no.	LSR D-6	LSRD-1	LSRD-2	LSRD-6	LSRD-6
LED life (Reference value)	Approx. 50,000 hours (The luminance is reduced to 50% the initial intensity when used on complete DC at 25°C.)				
Internal circuit	6 to 24V AC/DC		100/110V AC/DC		200/220V AC
<p>Symbol</p>					

• Only one color is available for LSRD so there are no color codes (*) to designate the color.

HW series short-body pilot lights

Package quantity: 1







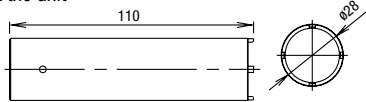

Name / Shape	Rated voltage	Part No.	* Illumination color code
Round flush HW1P-1 	6V AC/DC	HW1P-1JQ2 *	R (red) G (green) Y (yellow) A (amber) S (blue) PW (pure white)
	12V AC/DC	HW1P-1JQ3 *	
	24V AC/DC	HW1P-1JQ4 *	
	100/110V AC/DC	HW1P-1JRH2 *	
	200/220V AC	HW1P-1JCM2 *	
Extended (Dome) HW1P-2 	6V AC/DC	HW1P-2JQ2 *	
	12V AC/DC	HW1P-2JQ3 *	
	24V AC/DC	HW1P-2JQ4 *	
	100/110V AC/DC	HW1P-2JRH2 *	
	200/220V AC	HW1P-2JCM2 *	
Square flush HW2P-1 	6V AC/DC	HW2P-1JQ2 *	
	12V AC/DC	HW2P-1JQ3 *	
	24V AC/DC	HW2P-1JQ4 *	
	100/110V AC/DC	HW2P-1JRH2 *	
	200/220V AC	HW2P-1JCM2 *	

• See page 4 for maintenance LED lamps.

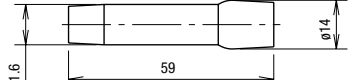
• For round flush and square flush pilot lights, legends and symbols can be engraved on marking plates, or printed film can be inserted. See page 4 for details on marking plates or film.
Engraving and films must be prepared by the customer.

Accessories / Maintenance parts

When ordering, specify the Ordering No.

Name / Shape	Specification	Part No.	Package quantity	Remarks	
	Metal (brass)	MW9Z-T1	1	Used to mount the unit on the panel. 	
	Rubber (black) Nitrile	OR-55	1	Used to install and remove the LED lamps. 	
 (1)  (2)  (3)	(1) For round flush units	Polyarylate ø23.5 H4.2	HW9Z-L11*-KPN05	5	* (Color code): R (red), G (green), Y (yellow) A (amber), C (clear), S (blue) (*1)
	(2) For square flush units	Polyarylate 24.6 H4	HW9Z-L21*-KPN05	5	* (Color code): R (red), G (green), Y (yellow) A (amber), C (clear), S (blue) (*1)
	(3) For extended (dome) units	AS resin ø23.5 H15.1	HW1A-P2*-KPN05	5	* (Color code): R (red), G (green), Y (yellow) A (amber), W (white), S (blue) (*2)
 (1)  (2)	(1) For round flush units	Acrylic ø21.5 t1	HW9Z-P11PN05	5	White
	(2) For square flush units	Acrylic □22.7 t1	HW9Z-P21PN05	5	White
	Nitril rubber ø28 t0.5	HW9Z-WMPN10	10	—	

*1) For round flush and square flush PW (pure white) illuminated color, use C (clear) lens.

*2) For dome PW (pure white) illuminated color, use W (white) lens.

Maintenance LED lamps

When ordering, specify the Ordering No.

Shape	Rated voltage	Current draw		Part No.	Ordering No.	Package quantity	Lamp base
		DC rating	AC rating				
	6V AC/DC	10mA	14mA	LSRD-6	LSRD-6	1	BA9S (*13)
					LSRD-6PN10	10	
	12V AC/DC	7mA	8mA	LSRD-1	LSRD-1	1	
					LSRD-1PN10	10	
	24V AC/DC	7mA	8mA	LSRD-2	LSRD-2	1	
					LSRD-2PN10	10	

• Only one color is available for LSRD so there are no color codes (*) to designate the color.

• When replacing maintenance LED lamps with LSRD lamps, the lens must also be replaced (sold separately. See Accessories / Maintenance Parts).

Dimensions

All dimensions in mm.

6V, 12V, 24V AC/DC

Round flush

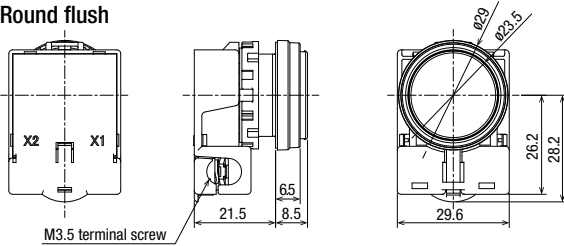

Square flush

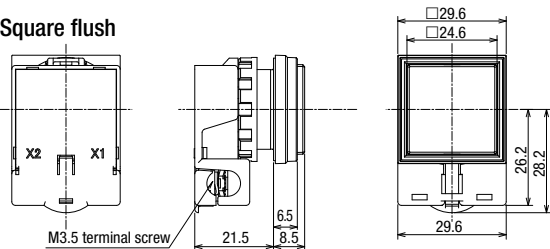

Extended (dome)

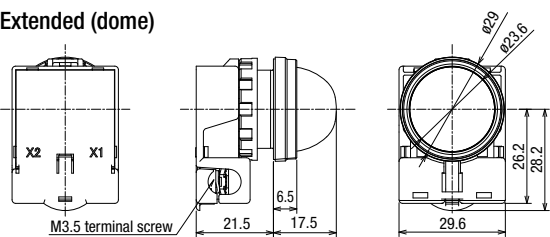

100/110V AC/DC, 200/220 AC

Round flush

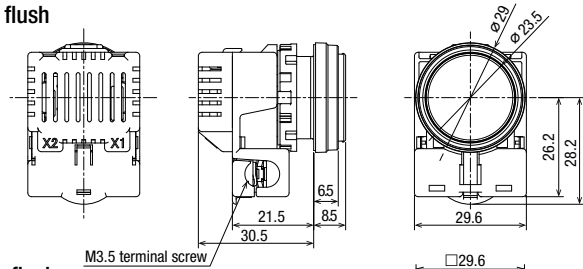

Square flush

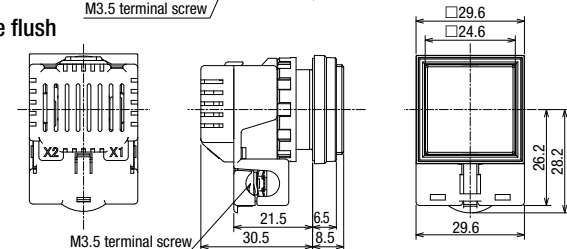

Extended (dome)

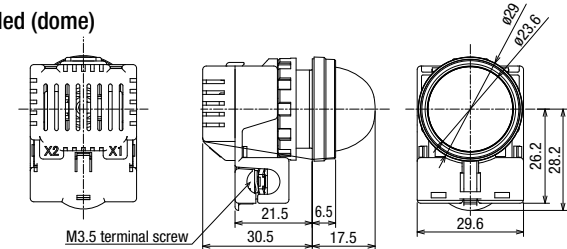

⚠ Safety Precautions

- Turn off the power before starting installation, removal, wiring, maintenance, and inspection of the products. Failure to turn power off may cause electrical shock or fire.
- To avoid burning your hand, use the lamp holder tool when replacing lamps.
- Tighten terminal screws to the proper tightening torque of 1.3N·m. Failure to tighten the terminal screws may cause overheating and fire.

Instructions

Panel mounting

Remove the operator from the transformer. Install the operator into the panel cut-out from the front and then attach the transformer unit.

Removing and Installing the power unit

- 1) Insert a flat screwdriver (5mm-wide max.) into the latch hole (A) on the transformer unit and disengage the latch. Then pull out the transformer unit.

For 6V, 12V, and 24V types

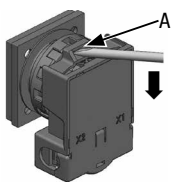

For 100V and 200V types

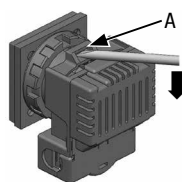

- 2) To install, place the TOP marking on the operator and the TOP marking and the transformer unit in the same direction and insert.

For 6V, 12V, and 24V types

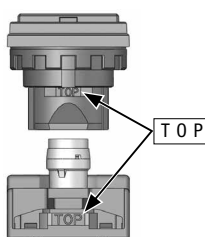

For 100V and 200V types

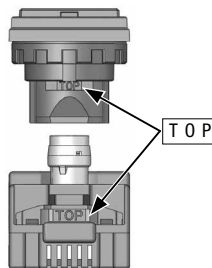

Marking

For square flush types, legends and symbols can be engraved on built-in marking plates, or a film can be inserted.

See IDEC website for more instructions.

Built-in marking plate and marking film size

All dimensions in mm.

	Built-in marking plate	Applicable marking film
Round flush	<p>Engraving area $\phi 19.6$ Dimensions $\phi 21.5$ Depth 0.5mm max</p>	<p>$\phi 21.5$ 19.4 Thickness 0.1mm x 2 sheets or 0.2mm x 1 sheet</p>
Square flush	<p>Engraving area $\square 19.9$ Dimensions $\square 22.7$ Depth 0.5mm max</p>	<p>$\square 22.7$ Thickness 0.1mm x 2 sheets or 0.2mm x 1 sheet</p>

Marking film is not provided.

Applicable wires

Use 2mm² wires (solid wire: $\phi 1.6$ max.) One or two wires can be connected to the terminal.

Applicable crimping terminal

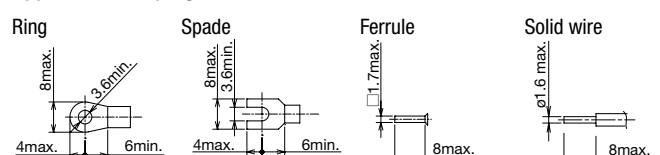

Ordering Terms and Conditions

Thank you for using IDEC Products.

By purchasing products listed in our catalogs, datasheets, and the like (hereinafter referred to as "Catalogs") you agree to be bound by these terms and conditions. Please read and agree to the terms and conditions before placing your order.

1. Notes on contents of Catalogs

- (1) Rated values, performance values, and specification values of IDEC products listed in this Catalog are values acquired under respective conditions in independent testing, and do not guarantee values gained in combined conditions.
Also, durability varies depending on the usage environment and usage conditions.
- (2) Reference data and reference values listed in Catalogs are for reference purposes only, and do not guarantee that the product will always operate appropriately in that range.
- (3) The specifications / appearance and accessories of IDEC products listed in Catalogs are subject to change or termination of sales without notice, for improvement or other reasons.
- (4) The content of Catalogs is subject to change without notice.

2. Note on applications

- (1) If using IDEC products in combination with other products, confirm the applicable laws / regulations and standards.
Also, confirm that IDEC products are compatible with your systems, machines, devices, and the like by using under the actual conditions. IDEC shall bear no liability whatsoever regarding the compatibility with IDEC products.
- (2) The usage examples and application examples listed in Catalogs are for reference purposes only. Therefore, when introducing a product, confirm the performance and safety of the instruments, devices, and the like before use. Furthermore, regarding these examples, IDEC does not grant license to use IDEC products to you, and IDEC offers no warranties regarding the ownership of intellectual property rights or non-infringement upon the intellectual property rights of third parties.
- (3) When using IDEC products, be cautious when implementing the following.
 - i. Use of IDEC products with sufficient allowance for rating and performance
 - ii. Safety design, including redundant design and malfunction prevention design that prevents other danger and damage even in the event that an IDEC product fails
 - iii. Wiring and installation that ensures the IDEC product used in your system, machine, device, or the like can perform and function according to its specifications
- (4) Continuing to use an IDEC product even after the performance has deteriorated can result in abnormal heat, smoke, fires, and the like due to insulation deterioration or the like. Perform periodic maintenance for IDEC products and the systems, machines, devices, and the like in which they are used.
- (5) IDEC products are developed and manufactured as general-purpose products for general industrial products. They are not intended for use in the following applications, and in the event that you use an IDEC product for these applications, unless otherwise agreed upon between you and IDEC, IDEC shall provide no guarantees whatsoever regarding IDEC products.
 - i. Use in applications that require a high degree of safety, including nuclear power control equipment, transportation equipment (railroads / airplanes / ships / vehicles / vehicle instruments, etc.), equipment for use in outer space, elevating equipment, medical instruments, safety devices, or any other equipment, instruments, or the like that could endanger life or human health
 - ii. Use in applications that require a high degree of reliability, such as provision systems for gas / waterworks / electricity, etc., systems that operate continuously for 24 hours, and settlement systems
 - iii. Use in applications where the product may be handled or used deviating from the specifications or conditions / environment listed in the Catalogs, such as equipment used outdoors or applications in environments subject to chemical pollution or electromagnetic interference
If you would like to use IDEC products in the above applications, be sure to consult with an IDEC sales representative.

3. Inspections

We ask that you implement inspections for IDEC products you purchase without delay, as well as thoroughly keep in mind management/maintenance regarding handling of the product before and during the inspection.

4. Warranty

(1) Warranty period

The warranty period for IDEC products shall be one (1) year after purchase or delivery to the specified location. However, this shall not apply in cases where there is a different specification in the Catalogs or there is another agreement in place between you and IDEC.

(2) Warranty scope

Should a failure occur in an IDEC product during the above warranty period for reasons attributable to IDEC, then IDEC shall replace or repair that product, free of charge, at the purchase location / delivery location of the product, or an IDEC service base. However, failures caused by the following reasons shall be deemed outside the scope of this warranty.

- i. The product was handled or used deviating from the conditions / environment listed in the Catalogs
- ii. The failure was caused by reasons other than an IDEC product
- iii. Modification or repair was performed by a party other than IDEC
- iv. The failure was caused by a software program of a party other than IDEC
- v. The product was used outside of its original purpose
- vi. Replacement of maintenance parts, installation of accessories, or the like was not performed properly in accordance with the user's manual and Catalogs
- vii. The failure could not have been predicted with the scientific and technical standards at the time when the product was shipped from IDEC
- viii. The failure was due to other causes not attributable to IDEC (including cases of force majeure such as natural disasters and other disasters)

Furthermore, the warranty described here refers to a warranty on the IDEC product as a unit, and damages induced by the failure of an IDEC product are excluded from this warranty.

5. Limitation of liability

The warranty listed in this Agreement is the full and complete warranty for IDEC products, and IDEC shall bear no liability whatsoever regarding special damages, indirect damages, incidental damages, or passive damages that occurred due to an IDEC product.

6. Service scope

The prices of IDEC products do not include the cost of services, such as dispatching technicians. Therefore, separate fees are required in the following cases.

- (1) Instructions for installation / adjustment and accompaniment at test operation (including creating application software and testing operation, etc.)
- (2) Maintenance inspections, adjustments, and repairs
- (3) Technical instructions and technical training
- (4) Product tests or inspections specified by you

The above content assumes transactions and usage within your region. Please consult with an IDEC sales representative regarding transactions and usage outside of your region. Also, IDEC provides no guarantees whatsoever regarding IDEC products sold outside your region.

IDEC CORPORATION

Head Office 6-64, Nishi-Miyahara-2-Chome, Yodogawa-ku, Osaka 532-0004, Japan

USA IDEC Corporation
EMEA APEM SAS

Singapore IDEC Izumi Asia Pte. Ltd.
Thailand IDEC Asia (Thailand) Co., Ltd.
India IDEC Controls India Private Ltd.

China IDEC (Shanghai) Corporation
IDEC Izumi (H.K.) Co., Ltd.
Taiwan IDEC Taiwan Corporation

Japan IDEC Corporation

 www.idec.com